



川源(中国)机械有限公司  
GSD (China) Co., Ltd.



# RSW/TRS

## 增压罗茨风机

RSW/TRS pressure boost roots blower

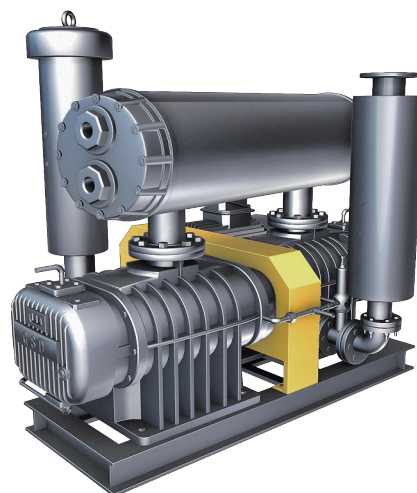

# RSW/TRS 增压罗茨风机

## RSW/TRS pressure boost roots blower

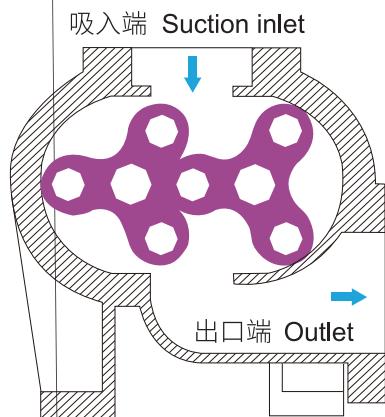

### 特点 Features

- 风量和压力范围大。
  - 口径：50mm~300mm (2"~12")
  - 风量：RSW 2.5~171.1m<sup>3</sup>/min; TRS 1.14~166.49m<sup>3</sup>/min
  - 压力：一段式RSW型可达10000mmAq (1.0kgf/cm<sup>2</sup>)
  - 二段式TRS型可达20000mmAq (2.0kgf/cm<sup>2</sup>)
- 排出气体不含油污。
- 电脑动平衡校正，低振动低噪音。
- 风量稳定，压力变换对风机之影响小。
- 特殊叶轮设计，高效率省能源。
- 构造简单坚固，无故障。
- 齿轮达到5级加工精度，寿命长，低噪音。
- 严格品质管理，标准化制品。
- 叶轮采用龙门刨床六轴加工法，无需重复定位装夹，一次精加工完成，使更换方便，其具有更高之精密密度。
- 特有的水冷却设计，可以有效的降低油箱和齿轮箱内的润滑油温度，确保风机高压运行轴承和齿轮的使用寿命。
- TRS两台风机串联运行，通过二次增压，使风机实现高压力。冷凝器的冷却系统，可有效的将第一段风机排出的气体降温，到达第二段入口的温度≤40℃，确保第二段风机正常运行。

### 原理 Theory

RSW/TRS 增压罗茨风机是一种容积式风机，其压力是可根据用户的要



## 外形结构图 Externality construction

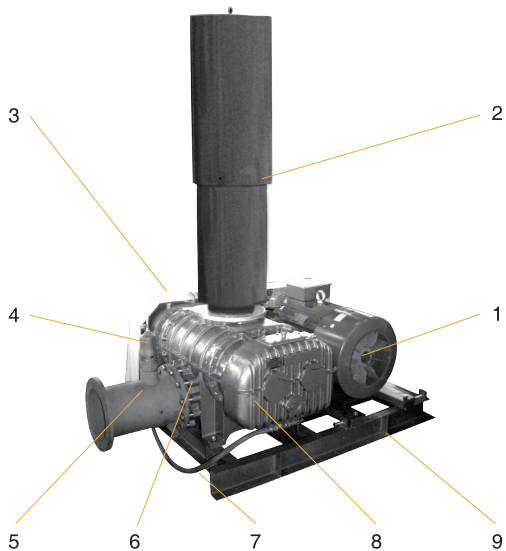

No.	名称	Name
1	电机	Motor
2	入口消音器	Inlet silencer
3	皮带护罩	Belt cover
4	泄压阀	Pressure release valve
5	三通管	T-joint
6	逆止阀	Check valve
7	冷却水管	Cooling pipe
8	风机本体	blower body
9	底座	Bottom case

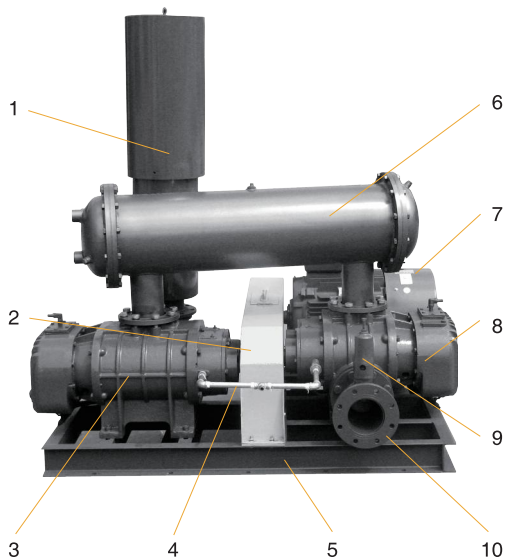

No.	名称	Name
1	入口消音器	Inlet silencer
2	皮带护罩	Belt cover
3	TRS一段风机	TRS one-stage blower
4	冷却水管	Cooling pipe
5	底座	Bottom case
6	冷凝器	Condenser
7	电机	Motor
8	TRS二段风机	TRS two-stage blower
9	泄压阀	Pressure release valve
10	三通管	T-joint

## 型号说明 Type description

RSW/TRS

65

口径 (mm)

Diameter (mm)

RSW/TRS增压罗茨风机 RSW/TRS pressure boost roots blower



## 结构简图 Construction

No.	名称 Name	材质 Material	Material	
			GB	JIS
1	风机机体 Casing	HT250	FC250	
2	轴承座 Bearing housing	HT250	FC250	
3	油箱 Oil box	HT250	FC250	
4	甩油片 Oil splash	Q235	SS400	
5	轴承固定片 Bearing washer	Q235	SS400	
6	骨架油封 Framework oil seal	NBR	NBR	
7	皮带轮 Pulley	HT250	FC250	
8	主动叶轮 Drive rotor	HT250	FC250	
9	被动叶轮 Driven rotor	HT250	FC250	
10	V封油封 V-ring	NBR	NBR	
11	轴承 Bearing	GCr15	SUJ2	
12	齿轮 Gear	20CrMnTi	SCM415	
13	止动垫片 Lock washer	Q235	SS400	
14	圆螺母 Lock nut	45	S45C	
15	齿轮箱 Gear box	HT250	FC250	
16	加油柱塞 Lubrication plug	45	S45C	
17	泄油柱塞 Purge plug	45	S45C	
18	润滑油面计 Oil gauge	Assembly	Assembly	

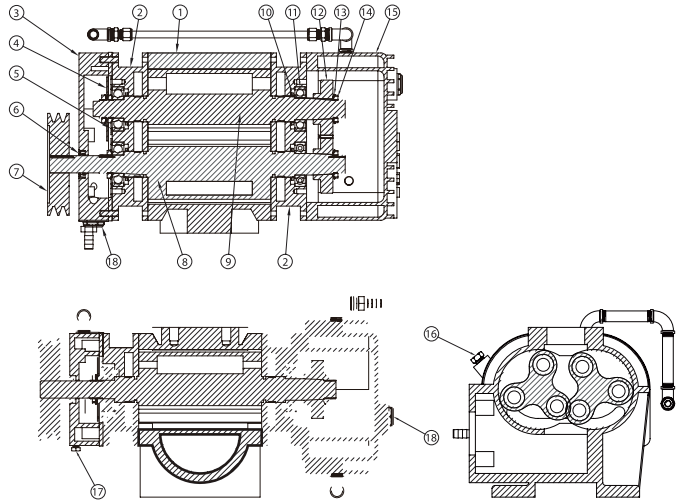

## 单位换算表 Conversion table

Pressure	atm	kPa	bar	lbt/in <sup>2</sup> (psi)	kgf/cm <sup>2</sup>	in Hg	ftAq	mmHg(Torr)	mmAq
1 atm	1	101.325	1.01325	14.696	1.0333	29.921	33.914	760	10333
1 kPa	0.0099	1	0.01	0.145	0.0102	0.295	0.335	7.5	102
1 bar	0.9869	100	1	14.504	1.0198	29.53	33.47	750	10198
1 lbt/in <sup>2</sup> (psi)	0.068	6.894	0.0689	1	0.0703	2.036	2.308	51.71	703
1 kgf/cm <sup>2</sup>	0.968	98.062	0.981	14.228	1	28.96	32.82	735.53	10000
1 inHg	0.0334	3.3863	0.0339	0.491	0.0345	1	1.133	25.4	345.3
1 ftAq	0.0295	2.99	0.0299	0.434	0.0305	0.882	1	22.42	304.8
1 mmHg(Torr)	0.013	0.1338	0.00138	0.019	0.0014	0.04	0.045	1	13.6
1 mmAq	0.000097	0.0098	0.000098	0.0014	0.0001	0.003	0.0033	0.074	1

Capacity	m <sup>3</sup> /min	l/min	cm <sup>3</sup> /s	in <sup>3</sup> /s	ft <sup>3</sup> /min(cfm)
1 m <sup>3</sup> /min	1	1000	16667	1016	35.288
1 l/min	0.001	1	16.67	1.02	0.0353
1 cm <sup>3</sup> /s	0.00006	0.06	1	0.061	0.02
1 in <sup>3</sup> /s	0.00098	0.983	16.39	1	0.035
1 ft <sup>3</sup> /min(cfm)	0.028	28.32	471.95	28.8	1

压力常用换算公式

Pressure Conversion Formula

1 kPa=1000Pa=1000N/m<sup>2</sup>

1mbar=10.198mmAq

1mmHg(Torr)=133.8Pa

## 性能参数 Performance parameters

型号 Type	转速 RPM	Qs(m³/min) Pressure(mmAq) La(kW)						冷却水量 (L/min)
		8000mmAq		9000mmAq		10000mmAq		
		Qs	La	Qs	La	Qs	La	
RSW50	1450	2.64	5.37	2.57	5.99	2.50	6.61	4
	1550	2.90	5.74	2.83	6.40	2.76	7.06	
	1650	3.16	6.11	3.09	6.82	3.02	7.52	
	1750	3.42	6.48	3.35	7.23	3.28	7.98	
	1850	3.68	6.85	3.61	7.64	3.54	8.43	
RSW65	1350	3.14	6.38	3.05	7.12	2.97	7.87	6
	1450	3.48	6.85	3.39	7.65	3.31	8.46	
	1550	3.82	7.32	3.73	8.18	3.65	9.04	
	1650	4.16	7.79	4.07	8.71	3.99	9.62	
RSW80	1300	5.87	11.03	5.75	12.30	5.64	13.57	8
	1400	6.47	11.87	6.35	13.24	6.24	14.61	
	1500	7.07	12.72	6.95	14.19	6.84	15.66	
	1600	7.67	13.57	7.55	15.14	7.44	16.70	
	1650	7.97	13.99	7.85	15.61	7.74	17.22	
	1750	8.57	14.84	8.45	16.55	8.34	18.27	
	1850	9.16	15.69	9.05	17.50	8.94	19.31	
RSW100	1200	7.42	14.47	7.26	16.12	7.11	17.76	10
	1300	8.26	15.68	8.10	17.46	7.95	19.24	
	1400	9.10	16.88	8.94	18.80	8.79	20.72	
	1500	9.94	18.09	9.78	20.14	9.63	22.20	
RSW125A	1180	11.67	20.54	11.49	22.91	11.33	25.28	12
	1250	12.53	21.76	12.35	24.27	12.19	26.78	
	1320	13.39	22.97	13.22	25.63	13.05	28.28	
	1390	14.25	24.19	14.08	26.98	13.91	29.78	
	1470	15.23	25.59	15.06	28.54	14.90	31.49	
	1560	16.34	27.15	16.17	30.28	16.00	33.42	
	1650	17.44	28.72	17.27	32.03	17.11	35.35	
	1750	18.67	30.46	18.50	33.97	18.34	37.49	
RSW125	1180	17.32	30.02	17.09	33.48	16.87	36.94	12
	1250	18.58	31.80	18.35	35.47	18.12	39.14	
	1320	19.84	33.58	19.60	37.45	19.38	41.33	
	1390	21.10	35.36	20.86	39.44	20.64	43.52	
	1470	22.53	37.39	22.30	41.71	22.08	46.02	
	1560	24.15	39.68	23.92	44.26	23.69	48.84	
	1650	25.77	41.97	25.53	46.82	25.31	51.66	
	1750	27.57	44.52	27.33	49.65	27.11	54.79	
RSW150	1180	29.36	47.06	29.13	52.49	28.91	57.92	15
	1250	24.09	41.00	23.79	45.73	23.51	50.46	
	1320	25.71	43.30	25.41	48.29	25.13	53.29	
	1390	27.33	45.59	27.03	50.86	26.75	56.12	
	1470	29.18	48.22	28.89	53.78	28.61	59.35	
RSW200A	990	31.27	51.17	30.97	57.08	30.69	62.98	15
	1050	30.61	52.09	30.23	58.10	29.88	64.11	
	1110	32.84	55.25	32.46	61.62	32.11	67.99	
	1180	35.07	58.40	34.69	65.14	34.34	71.88	
	1250	37.67	62.08	37.29	69.25	36.94	76.41	
	1320	40.27	65.77	39.89	73.36	39.54	80.95	
	1390	42.87	69.45	42.50	77.46	42.14	85.48	
	1390	45.47	73.13	45.10	81.57	44.74	90.01	



## 性能参数 Performance parameters

型号 Type	转速 RPM	Qs(m³/min) Pressure(mmAq) La(kW)						冷却水量 (L/min)
		8000mmAq		9000mmAq		10000mmAq		
		Qs	La	Qs	La	Qs	La	
RSW200	990	40.39	66.97	39.97	74.70	39.57	82.43	25
	1050	43.25	71.03	42.83	79.23	42.44	87.42	
	1110	46.12	75.09	45.70	83.75	45.30	92.42	
	1180	49.47	79.82	49.05	89.03	48.65	98.24	
	1250	52.81	84.56	52.39	94.32	51.99	104.07	
	1320	56.16	89.29	55.74	99.60	55.34	109.90	
	1390	59.50	94.03	59.08	104.88	58.68	115.73	
RSW250	1050	58.80	94.71	58.31	105.63	57.84	116.56	25
	1110	62.62	100.12	62.13	111.67	61.66	123.22	
	1180	67.08	106.43	66.59	118.71	66.12	130.99	
	1250	71.54	112.75	71.05	125.75	70.58	138.76	
	1320	76.00	119.06	75.51	132.80	75.04	146.53	
	1390	80.46	125.37	79.97	139.84	79.50	154.30	
	1470	85.56	132.59	85.07	147.89	84.60	163.19	
RSW300	600	64.17	113.54	63.19	139.29	62.27	161.39	30
	700	77.54	132.47	76.56	159.94	75.64	184.23	
	800	90.90	151.39	89.93	180.59	89.01	207.06	
	900	104.27	170.32	103.30	201.25	102.38	229.90	
	1000	117.64	189.24	116.67	221.90	115.75	252.73	
	1100	131.01	208.16	130.04	242.55	129.12	275.57	
	1200	144.38	227.09	143.41	263.20	142.48	298.40	
	1300	157.75	246.01	156.77	283.85	155.85	321.24	
1400	171.12	264.94	170.14	304.51	169.22	344.07		







## 性能参数 Performance parameters

Qs(m³/min) Pressure(mmAq) La(kW)

型号 Type	转速 RPM	10000mmAq		11000mmAq		12000mmAq		13000mmAq		14000mmAq		15000mmAq		16000mmAq		17000mmAq		18000mmAq		19000mmAq		20000mmAq		冷却水量 (L/min)
		Qs	La	Qs	La	Qs	La	Qs	La	Qs	La	Qs	La	Qs	La	Qs	La	Qs	La	Qs	La	Qs	La	
TRS200	990	36.10	74.66	35.65	82.13	35.20	89.59	34.80	97.06	34.40	104.52	33.70	109.95	33.01	115.38	32.83	124.89	32.65	134.39	31.75	141.85	30.84	149.32	135
	1050	38.90	79.19	38.45	87.10	38.00	95.02	37.60	102.94	37.20	110.86	36.48	116.74	35.76	122.62	35.64	132.58	35.51	142.53	34.61	150.45	33.71	158.37	
	1110	41.60	83.71	41.15	92.08	40.70	100.45	40.25	108.82	39.80	117.19	39.16	123.53	38.51	129.86	38.45	140.27	38.38	150.68	37.48	159.05	36.58	167.42	
	1180	44.80	88.99	44.35	97.89	43.90	106.79	43.50	115.69	43.10	124.58	42.41	131.11	41.72	137.63	41.73	148.91	41.73	160.18	40.83	169.08	39.92	177.98	
	1250	48.00	94.27	47.55	103.70	47.10	113.12	46.70	122.55	46.30	131.98	45.62	139.03	44.94	146.08	45.00	157.88	45.07	169.68	44.17	179.11	43.27	188.54	
	1320	51.20	99.55	50.75	109.50	50.30	119.46	49.90	129.41	49.50	139.37	48.82	146.95	48.15	154.52	48.28	166.85	48.42	179.18	47.52	189.14	46.61	199.09	
	1390	54.40	104.83	54.00	115.31	53.60	125.79	53.15	136.27	52.70	146.76	52.03	154.86	51.36	162.97	51.56	175.83	51.76	188.69	50.86	199.17	49.96	209.65	
TRS250	990	49.60	97.99	49.15	107.79	48.70	117.59	48.20	127.39	47.70	137.19	47.18	146.99	46.67	156.79	46.14	166.59	45.60	176.39	45.05	186.18	44.50	195.98	150
	1050	53.30	103.93	52.80	114.32	52.30	124.72	51.85	135.11	51.40	145.50	50.89	155.90	50.38	166.29	49.86	176.68	49.35	187.08	48.84	197.47	48.32	207.86	
	1110	57.00	109.87	56.50	120.86	56.00	131.84	55.50	142.83	55.00	153.82	54.54	164.80	54.09	175.79	53.59	186.78	53.10	197.77	52.62	208.75	52.15	219.74	
	1180	61.30	116.80	60.80	128.48	60.30	140.16	59.80	151.84	59.30	163.52	58.86	175.20	58.41	186.88	57.94	198.56	57.47	210.24	57.04	221.92	56.61	233.60	
	1250	65.50	123.73	65.00	136.10	64.50	148.47	64.05	160.85	63.60	173.22	63.17	185.59	62.74	197.96	62.29	210.34	61.84	222.71	61.45	235.08	61.07	247.45	
	1320	69.80	130.66	69.30	143.72	68.80	156.79	68.35	169.85	67.90	182.92	67.48	195.98	67.07	209.05	66.64	222.11	66.21	235.18	65.87	248.25	65.53	261.31	
	1390	74.10	137.58	73.60	151.34	73.10	165.10	72.55	178.86	72.00	192.62	71.70	206.38	71.39	220.14	70.99	233.89	70.58	247.65	70.28	261.41	69.99	275.17	
TRS300	700	73.90	169.83	72.90	184.60	71.90	199.37	71.05	215.98	70.20	232.60	69.42	246.38	68.65	260.17	67.47	276.43	66.30	292.69	65.13	308.95	63.97	325.21	200
	800	87.30	194.09	86.30	210.97	85.30	227.85	84.45	246.84	83.60	265.82	82.81	281.58	82.02	297.33	80.84	315.92	79.67	334.50	78.50	353.08	77.34	371.67	
	900	100.80	218.35	99.80	237.34	98.80	256.33	97.95	277.69	97.10	299.05	96.24	316.78	95.39	334.50	94.21	355.41	93.04	376.31	91.87	397.22	90.70	418.13	
	1000	114.10	242.62	113.10	263.71	112.10	284.81	111.25	308.54	110.40	332.28	109.58	351.97	108.75	371.67	107.58	394.90	106.41	418.13	105.24	441.36	104.07	464.58	
	1100	127.60	266.88	126.60	290.08	125.60	313.29	124.75	339.40	123.90	365.51	123.01	387.17	122.12	408.83	120.95	434.39	119.77	459.94	118.61	485.49	117.44	511.04	
	1200	141.00	291.14	140.00	316.46	139.00	341.77	138.15	370.25	137.30	398.73	136.40	422.37	135.49	446.00	134.32	473.88	133.14	501.75	131.98	529.63	130.81	557.50	
	1300	154.60	315.40	153.60	342.83	152.60	370.25	151.75	401.11	150.90	431.96	149.88	457.57	148.86	483.17	147.69	513.37	146.51	543.56	145.35	573.76	144.18	603.96	
	1400	166.49	339.66	165.42	369.20	164.34	398.73	163.42	431.96	162.51	465.19	162.37	492.76	162.23	520.33	161.05	552.86	159.88	585.38	158.71	617.90	157.55	650.42	

## RSW外形尺寸图 RSW Installation dimensions

配用卧式出口消音器 (RSW with horizontal outlet silencer)

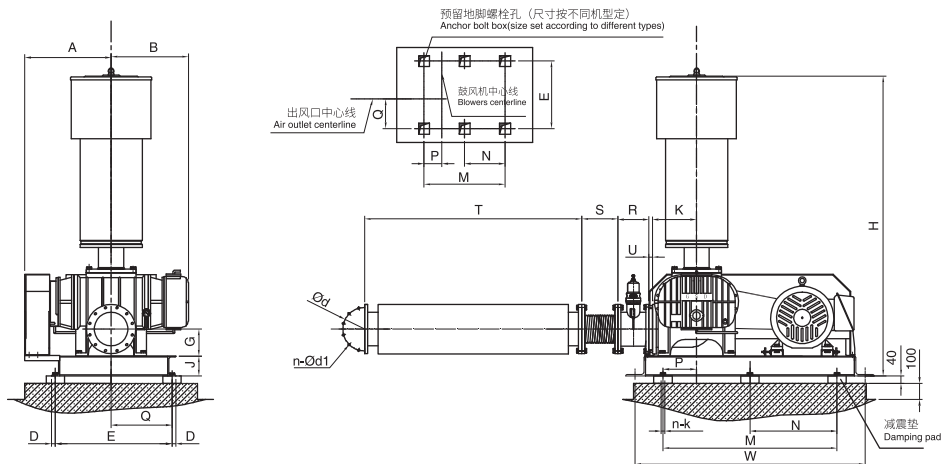

单位 Unit: (mm)

型号 Type	A	B	D	E	G	H	J	K	M	N	W	P	Q	R	S	T	U	Ød	n-Ød1	n-k
RSW40	235	274	25	350	104	741	56	140	500	-	700	93	266	150	160	595	18	110	4-Ø18	4-M12x160
RSW50	300	314	20	412	103.5	921	80	140	520	-	700	93	231	150	180	595	18	125	4-Ø18	4-M12x160
RSW65	323	344	20	412	104	924	80	152	520	-	700	93	208.5	150	208	595	18	145	4-Ø18	4-M12x160





单位 Unit: (mm)

型号 Type	A	B	D	E	G	H	J	K	M	N	W	P	Q	R	S	T	U	Ød	n-Ød1	n-k
RSW80	383	320	20	482	106.5	1241	80	180	700	-	700	112.5	238	180	256	795	22	160	8-Ø18	4-M12×160
RSW100	426	370	20	482	110	1245	80	180	700	-	700	131	194	180	280	795	22	180	8-Ø18	4-M16×220
RSW125A	485	402	24	602	135	1840	100	250	950	-	950	178	291	250	330	1260	22	210	8-Ø18	4-M16×220
RSW125	505	462	24	602	157.5	1835	100	262	950	-	950	181.5	271	250	330	1260	22	210	8-Ø18	4-M16×220
RSW150	564	521.6	24	602	163.5	1860	100	250	950	-	950	182	212	250	378	1260	22	240	8-Ø23	4-M16×220
RSW200A	519.5	521	30	790	198	2285	160	358	1300	650	-	312.5	441	250	530	1645	25	295	8-Ø23	6-M20×300
RSW200	565	571	30	940	194	2285	160	345	1300	650	-	310	391	250	530	1645	25	295	8-Ø23	6-M20×300
RSW250	695	646	30	940	216	2520	160	356	1400	700	-	270	490	250	450	1750	38	350	12-Ø23	6-M20×300
RSW300	840	688	35	1030	300	2955	250	510	2000	1000	-	321	485	300	510	1850	38	400	12-Ø23	6-M20×300

注：1.当RSW-150配电机功率在55kW以上，风机底座尺寸另询。  
2.当RSW-200、RSW-200A配电机功率在90kW以上，风机底座尺寸另询。

Note: 1.When the motor power of RSW-150 is above 55kW, the size of the blower base should be specifically confirmed.  
2.When the motor power of RSW-200 and RSW-200A is above 90kW, the size of the blower base should be specifically confirmed.

### 配用立式出口消音器(RSW with vertical outlet silencer)

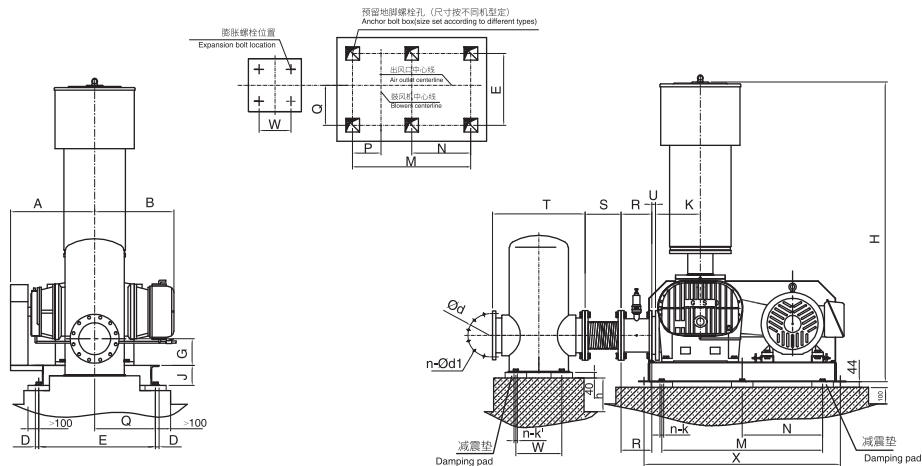

单位 Unit: (mm)

型号 Type	A	B	D	E	G	H	h	J	K	M	N	X	P	Q	R	S	T	U	W	d	n-Ød1	h	地脚螺栓 n-k	地脚螺栓 n-k'
RSW50	300	314	20	412	103.5	921	163.5	80	140	520	-	700	93	231	150	180	595	18	140	125	4-Ø18	63.5	4-M12×160	4-M12×120
RSW65	323	344	20	412	104	924	154	80	152	520	-	700	93	208.5	150	208	595	18	170	145	4-Ø18	54	4-M12×160	4-M12×120
RSW80	383	320	20	482	106.5	1241	141.5	80	180	180	-	900	112.5	238	180	256	795	22	190	160	8-Ø18	41.5	4-M12×160	4-M12×120
RSW100	426	370	20	482	110	1245	135	80	180	180	-	900	130.5	195	180	280	795	22	240	180	8-Ø18	35	4-M16×220	4-M12×120
RSW125A	485	402	24	602	135	1840	145	100	250	250	-	1150	178	291	250	330	1260	22	240	210	8-Ø18	45	4-M16×220	4-M12×120
RSW125	505	462	24	602	157.5	1835	167.5	100	262	262	-	1150	182	271	250	330	1260	22	240	210	8-Ø18	67.5	4-M16×220	4-M12×120
RSW150	564	521.6	24	602	163.5	1860	153	100	250	250	-	1150	182	212	250	378	1260	22	290	240	8-Ø23	53.5	4-M16×220	4-M12×120
RSW200A	519.5	521	30	790	198	2285	202	100	358	358	650	-	313	441	250	530	1645	25	350	295	8-Ø23	102	6-M20×300	4-M12×120
RSW200	565	571	30	940	194	2285	198	100	345	345	650	-	310	391	250	530	1645	25	350	295	8-Ø23	98	6-M20×300	4-M12×120

注：1.当RSW-150配电机功率在55kW以上，风机底座尺寸另询。  
2.当RSW-200、RSW-200A配电机功率在90kW以上，风机底座尺寸另询。

Note: 1.When the motor power of RSW-150 is above 55kW, the size of the blower base should be specifically confirmed.  
2.When the motor power of RSW-200 and RSW-200A is above 90kW, the size of the blower base should be specifically confirmed.



## TRS外形尺寸图 TRS Installation dimensions

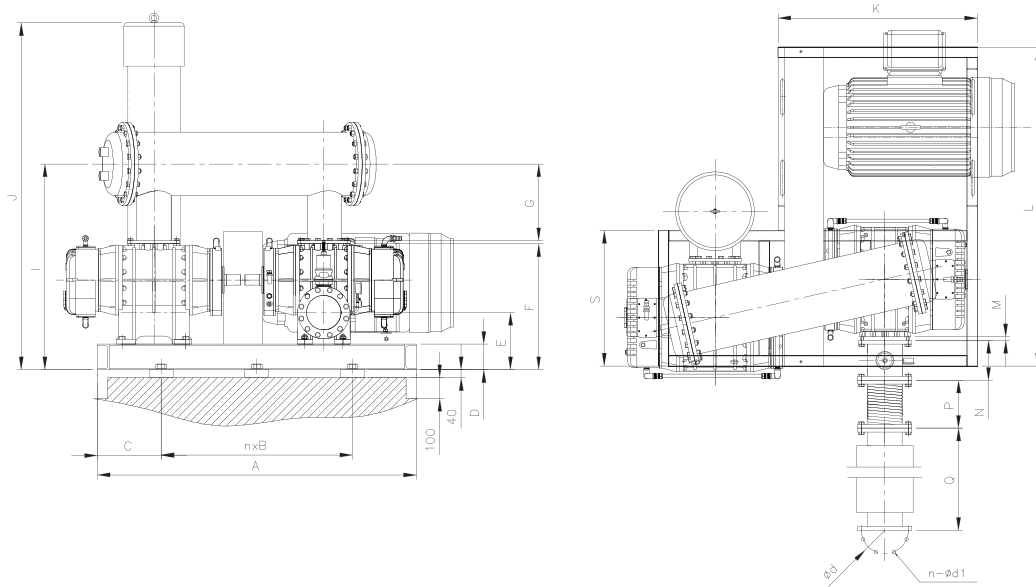

单位 Unit: (mm)

型号 Type	A	nxB	C	D	E	F	G	I	J	K	L	M	N	P	Q	S	Ød	n-Ød1
TRS50	1150	2x430	120	80	184	365	200	565	844	650	1000	18	150	160	595	320	110	4-Ø18
TRS65	1150	2x430	120	80	184	371	240	611	889	650	1000	18	150	180	595	320	125	4-Ø18
TRS80	1400	3x300	250	120	226	414	240	654	1214	800	1200	22	180	256	795	381	160	8-Ø18
TRS100	1400	3x300	250	120	226	414	250	664	1214	800	1200	22	180	256	795	381	160	8-Ø18
TRS125	1700	5x300	250	120	255	550	350	900	1790	880	1479	22	250	330	1260	560	210	8-Ø18
TRS150	1700	5x300	250	120	255	550	425	975	1833	880	1479	22	250	330	1260	560	210	8-Ø18
TRS200A	2000	4x400	200	160	358	785	600	1385	2173	1250	2000	25	250	530	1645	850	295	8-Ø23
TRS200	2000	4x400	200	160	358	785	700	1485	2169	1250	2000	25	250	530	1645	850	295	8-Ø23
TRS250	2150	4x450	175	160	354	785	555	1340	2497	1250	2000	25	250	530	1645	850	295	8-Ø23
TRS300	2900	5x500	200	200	500	1080	600	1680	2795	1500	2850	38	300	510	1850	1206	400	12-Ø23

## 地脚螺栓 Anchor bolt

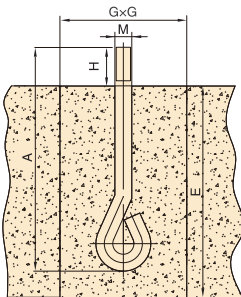

地脚螺栓 M Anchor bolt GB799-88	A	H	E	GxG	适用型号 Application type
M12	160	36	224	100x100	RSW/TRS50,65,80,100
M16	220	45	275	120x120	RSW/TRS125,150; RSW125A
M20	300	55	345	150x150	RSW/TRS200A,200,250,300A,300

注：1.图注E为最小尺寸，根据安装的土壤情况，应当加深。

2.GxG为二次浇灌前的预留孔尺寸。

Note:1. The note E on the drawing is the minimum size, it shall be deepened properly according to the soil condition in the installation place.

2. GxG is the size of the preformed holes for the secondary casting.



## 入口消音器 Suction silencer

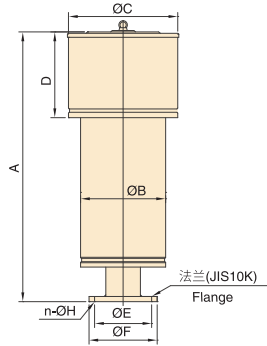

单位 Unit: (mm)

型号 Type	A	B	C	D	E	F	n-ØH	重量 Weight (kg)	适用型号 Application type
SS50	550	133	150	220	120	155	4-Ø19	10	RSW50 TRS50
SS65	550	159	190	280	140	175	4-Ø19	12	RSW65 TRS65
SS80	820	219	245	280	150	185	8-Ø19	21	RSW80 TRS80
SS100	820	245	273	330	175	210	8-Ø19	27	RSW100 TRS100
SS125	1310	273	310	350	210	250	8-Ø23	45	RSW125(A) TRS125
SS150	1310	299	340	370	240	280	8-Ø23	52	RSW150 TRS150
SS200	1500	330	380	370	290	330	12-Ø23	81	RSW200(A) TRS200(A)
SS250	1700	400	480	550	355	400	12-Ø25	98	RSW250 TRS250
SS300	1825	500	600	650	400	445	16-Ø25	135	RSW300 TRS300

## 卧式出口消音器 Horizontal outlet silencer

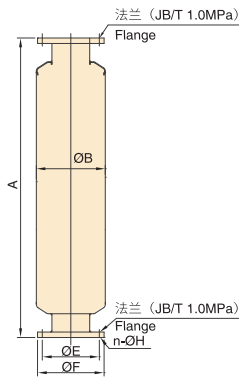

单位 Unit: (mm)

型号 Type	A	B	E	F	n-ØH	重量 Weight (kg)	适用型号 Application type
DS40	595	159	110	145	4-Ø18	11	TRS50
DS50	595	159	125	160	4-Ø18	12	RSW50 TRS65
DS65	595	159	145	180	4-Ø18	13.5	RSW65
DS80	795	219	160	195	8-Ø18	24	RSW80 TRS80 TRS100
DS100	795	219	180	215	8-Ø18	25	RSW100
DS125	1260	290	210	245	8-Ø18	48	RSW125(A) TRS125 TRS150
DS150	1260	290	240	280	8-Ø23	51	RSW150
DS200	1645	356	295	335	8-Ø23	79	RSW200(A) TRS200(A) TRS250
DS250	1750	405	350	390	12-Ø23	98	RSW250
DS300	1850	484	400	440	12-Ø23	140	RSW300 TRS300

## 立式出口消音器 Vertical outlet silencer

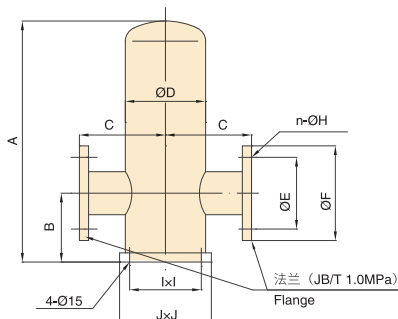

单位 Unit: (mm)

型号 Type	A	B	C	D	E	F	n-ØH	I	J	重量 Weight (kg)	适用型号 Application type
VDS50	420	120	150	140	125	160	4-Ø18	125	160	19	RSW50
VDS65	480	130	175	191	145	180	4-Ø18	170	210	27	RSW65
VDS80	595	145	200	216	160	195	8-Ø18	190	235	36.9	RSW80
VDS100	660	155	225	267	180	215	8-Ø18	230	280	51.8	RSW100
VDS125	800	190	250	280	210	245	8-Ø18	240	300	65.9	RSW125(A)
VDS150	920	210	300	356	240	280	8-Ø23	290	376	99.6	RSW150
VDS200	1050	256	325	406	295	335	8-Ø23	350	425	131.5	RSW200(A)



## 三通管 "T"-joint

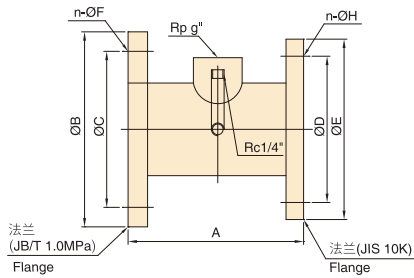

单位 Unit: (mm)

型号 Type	A	B	C	n-ØH	g	E	D	n-ØH	重量 Weight (kg)	适用型号 Application type
HJ40	150	145	110	4-Ø18	1 1/4"	155	120	4-Ø19	5.5	TRS50
HJ50	150	160	125	4-Ø18	1 1/4"	155	120	4-Ø19	5.8	RSW50 TRS65
HJ65	150	180	145	4-Ø18	1 1/4"	175	140	4-Ø19	7.5	RSW65
HJ80	180	195	160	8-Ø18	1 1/4"	185	150	8-Ø19	9	RSW80 TRS80 TRS100
HJ100	180	215	180	8-Ø18	2"	210	175	8-Ø19	11.5	RSW100
HJ125	250	245	210	8-Ø18	2"	250	210	8-Ø23	15.5	RSW125(A) TRS125 TRS150
HJ150	250	280	240	8-Ø23	2"	280	240	8-Ø23	18	RSW150
HJ200	250	335	295	8-Ø23	3"	330	290	12-Ø23	23	RSW200(A) TRS200(A) TRS250
HJ250	250	390	350	12-Ø23	3"	400	355	12-Ø25	30	RSW250
HJ300	300	440	400	12-Ø23	DN100	445	400	16-Ø25	45	RSW300 TRS300

注：DN100为法兰连接，参考JB/T1.0MPa规范尺寸。  
Note: Type DN100 is connect with flange. Refer to JB/T 1.0MPa.

## 泄压阀 Relief valve

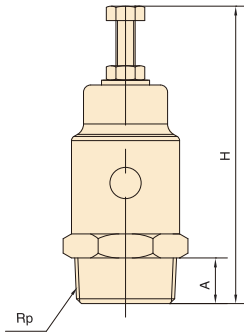

单位 Unit: (mm)

型号 Type	A	H	重量 Weight (kg)	适用型号 Application type
SV1 1/4"	19	145	0.3	RSW40、50、65、80 TRS50、65、100
SV2"	24	185	1	RSW100、125(A)、150 TRS125、150
SV3"	30	230	1.6	RSW200(A)、250 TRS200(A)、250
SV100	90	490	29	RSW300 TRS300

注：SV100为法兰连接，参考JB/T 1.0MPa法兰标准。  
Note: Type SV100 is connect with flange. Refer to JB/T 1.0MPa.

## 逆止阀 Check valve

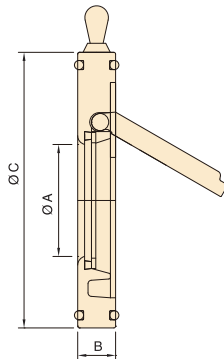

单位 Unit: (mm)

型号 Type	A	B	C	重量 Weight (kg)	适用型号 Application type
DCV-50	37	18	102.5	1	RSW50 TRS50 TRS65
DCV-65	45	18	122.5	1.4	RSW65
DCV-80	52	22	132	0.8	RSW80 TRS80 TRS100
DCV-100	65	22	158	0.9	RSW100
DCV-125	90	22	190	1.2	RSW125(A) TRS125 TRS150
DCV-150	115	22	215	1.5	RSW150
DCV-200	160	25	268	2.6	RSW200(A) TRS200(A) TRS250
DCV-250	180	38	325	12.5	RSW250
DCV-300	213	38	375	18.5	RSW300 TRS300

## TRS 弯头 TRS elbow

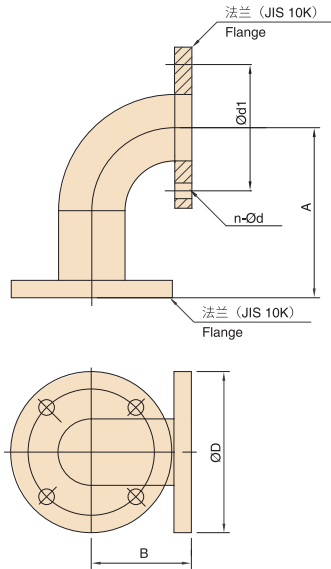

单位 Unit: (mm)

适用型号 Application Type	A	B	D	d1	n-Ød
TRS50	200	110	155	120	4-Ø19
TRS65	200	155	175	140	4-Ø19
TRS80	220	168	185	150	8-Ø19
TRS100	250	164	210	175	8-Ø19
TRS125	300	202	250	210	8-Ø23
TRS150	320	240	280	240	8-Ø23
TRS200(A)	315	315	330	290	12-Ø23
TRS250	350	421	400	355	12-Ø25
TRS300	470	470	445	400	16-Ø25

## TRS 冷凝器 Condenser

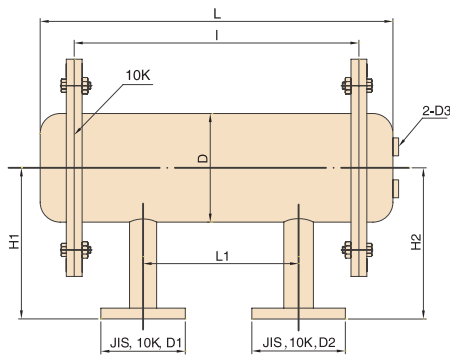

单位 Unit: (mm)

型号 Type	D	D1	D2	H1	H2	L	I	L1	D3 (内螺纹)	适用型号 Application Type
25	8"	2"	1.5"	194	200	900	660	554	3/4"	TRS50
30	8"	2.5"	2"	237	240	1000	800	594	3/4"	TRS65
35	10"	3"	3"	193	240	1200	900	747	1"	TRS80
40	10"	4"	3"	199	250	1300	1000	795	1"	TRS100
50	12"	5"	5"	355	350	1400	1200	907	1"	TRS125
60	14"	6"	5"	405	425	1500	1120	961	1"	TRS150
80	16"	8"	8"	600	600	1600	1200	999	1"	TRS200A
90	18"	8"	8"	700	700	1700	1250	1077	2"	TRS200
100	20"	10"	8"	520	555	2200	1800	1229	2"	TRS250
140	24"	12"	12"	600	600	2600	2000	1571	2"	TRS300

## 波纹管 Bellows

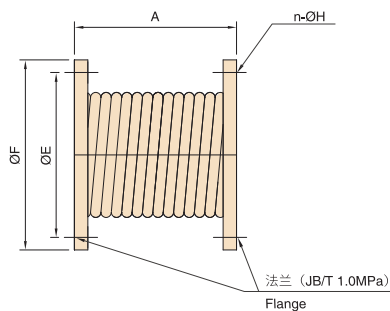

单位 Unit: (mm)

型号 Type	A	E	F	n-ØH	适用型号 Application Type
WJT-40	160	Ø110	Ø150	4-Ø18	RSW40 TRS50
WJT-50	180	Ø125	Ø165	4-Ø18	RSW50 TRS65
WJT-65	208	Ø145	Ø185	4-Ø18	RSW65
WJT-80	256	Ø160	Ø200	8-Ø18	RSW80 TRS80~100
WJT-100	280	Ø180	Ø220	8-Ø18	RSW100
WJT-125	330	Ø210	Ø250	8-Ø18	RSW125(A) TRS125~150
WJT-150	378	Ø240	Ø285	8-Ø22	RSW150
WJT-200	530	Ø295	Ø340	8-Ø22	RSW200(A) TRS200A~250
WJT-250	450	Ø350	Ø395	12-Ø22	RSW250
WJT-300	510	Ø400	Ø455	12-Ø22	RSW/TRS300



## 用途说明 Applications

水处理  
Water treatment



**1** 用于污水处理厂的曝气处理  
Aeration of sewage

烟气脱硫  
FGD

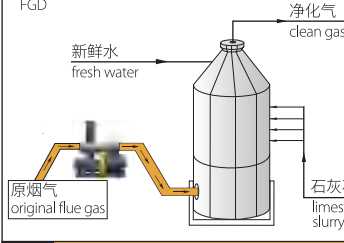

新鲜水  
fresh water

原烟气  
original flue gas

净化气  
clean gas

石灰石浆  
limestone slurry

**2** 用于工业烟气脱硫的气体输送  
For FGD's gas delivery system

物料输送  
Conveying

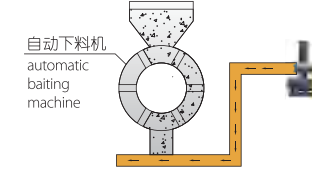

自动下料机  
automatic baiting machine

**3** 利用气体运动将物料输送  
Use gas conveying materials

燃烧炉  
Incinerator

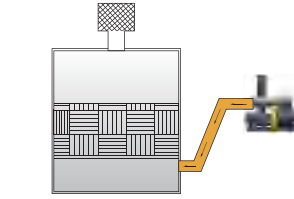

**4** 用于助燃，增加氧气促进燃烧  
Used for combustion, increasing oxygen to promote combustion

啤酒厂、饮料行业  
Brewery and beverage industry

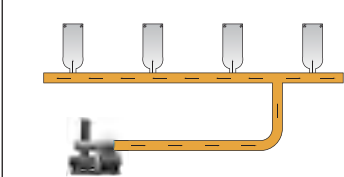

**5** 用于气体运动将瓶内死角清理干净  
Clean up the bottle's dead angle by gas

发酵厂  
Fermenting plant

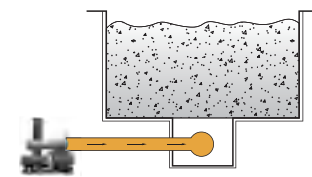

**6** 通过增加含氧量，来促进发酵  
Increasing oxygen to promote the fermentation

喷涂  
Spray finishing

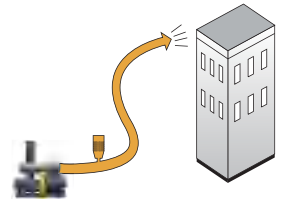

**7** 通过气体将防火材料喷涂到墙上或钢筋结构上  
Use gas spraying fire-resistant material on the wall

洗车  
Car washing



清洗剂  
cleaning agent

**8** 洗车厂通过虹吸现象带动洗车液清洗车辆  
Use washing fluid washing car base on siphon principle

电镀行业  
Electroplate factory

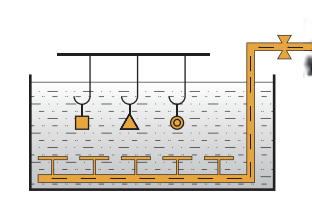

**9** 利用气体使液体均匀化，液体与工件充分接触  
Stir gas liquid, make its uniformity

如蒙洽询请指示下列各项：  
For further details, please fulfill the chart below.

客户 \_\_\_\_\_ 承办人员 \_\_\_\_\_  
Customer \_\_\_\_\_ Undertaker \_\_\_\_\_

工程名称 \_\_\_\_\_ 工程地点 \_\_\_\_\_  
Name of project \_\_\_\_\_ Address of project \_\_\_\_\_

电话 \_\_\_\_\_ 传真 \_\_\_\_\_  
Telephone \_\_\_\_\_ Fax \_\_\_\_\_

* 当地状况 Local condition	海拔m Elevation		最高相对湿度% Max relative humidity	
	当地大气压力(MPa) Local atmospheric pressure		最高气温(°C) Max air temperature	
* 气体性质 Gas character	名称 Name		温度(°C) Temperature	
	成份 Constituents		各组分比例 Ratio of constituent	
风机参数 Blower's parameter	* 风量(m <sup>3</sup> /min) Capacity		口径(mm) Diameter	
	* 风压(mmAq) Pressure		转速(r/min) Speed	
电机参数 Motor's parameter	型式 Type		电压(V) Voltage	
	功率(kW) Power		频率(Hz) Frequency	
	极数 Pole		其它 Others	
安装位置 Location	<input type="checkbox"/> 室内安装 Indoor install	<input type="checkbox"/> 遮雨棚式室外安装 Camping outdoor install	<input type="checkbox"/> 其它 Others _____	
* 传动方式 Driving mode	<input type="checkbox"/> 皮带传动(标准型) Belt-driven(Standard)		<input type="checkbox"/> 直联传动 Direct drive	
其它要求 Other requirement				

备注：1.以上资料请尽可能完整填写。  
2.项目前加注“\*”者，请务必填写。  
Notes: 1. Please fill in the parameter lists as complete as possible.  
2. The item with “\*” must be filled.





欢迎索取以下产品型录



泵系列

潜水泵系列 | 陆上泵系列 | 特种泵系列



搅拌推流系列

搅拌机系列 | 推流器系列



供氧曝气系列

曝气机系列 | 曝气盘系列 | 曝气管系列



风机系列

磁悬浮鼓风机 | 空气悬浮鼓风机 | 三叶罗茨鼓风机系列



污泥处理设备

带式脱水机 | 厢式压滤机 | 叠螺式脱水机 | 污泥干化设备 | 浅层高效气浮设备



智能化系列

智能设备 | 水务设备健康管理 | 水务系统工艺优化智联管理



反应器及套装设备

芬顿反应系统 | MBR生物膜反应器 | 预制泵站 | 一体化污水处理设备



耗材药剂及相关设备

生物绳 | PAC 聚合氯化铝 | PAM 聚丙烯酰胺 | 泡药设备

GSD 的经营理念

G-Green 绿色 S-Safe 安全 D-Development 永续经营



川源

水处理系统专业合作伙伴

免费咨询电话

400-657-9066

数据来源：公司实验室数据及客户实际使用数据，具体使用环境不同，数据可能存在差异。

The data on the brochure is based on the laboratory testing data and customers' actual operation data in the past. The actual data may be different in different application conditions.

本型录内容如有变更，恕不另行通知。

We reserve the right to change content without notice.

川源（中国）机械有限公司版权所有 all rights reserved. CY-35

