

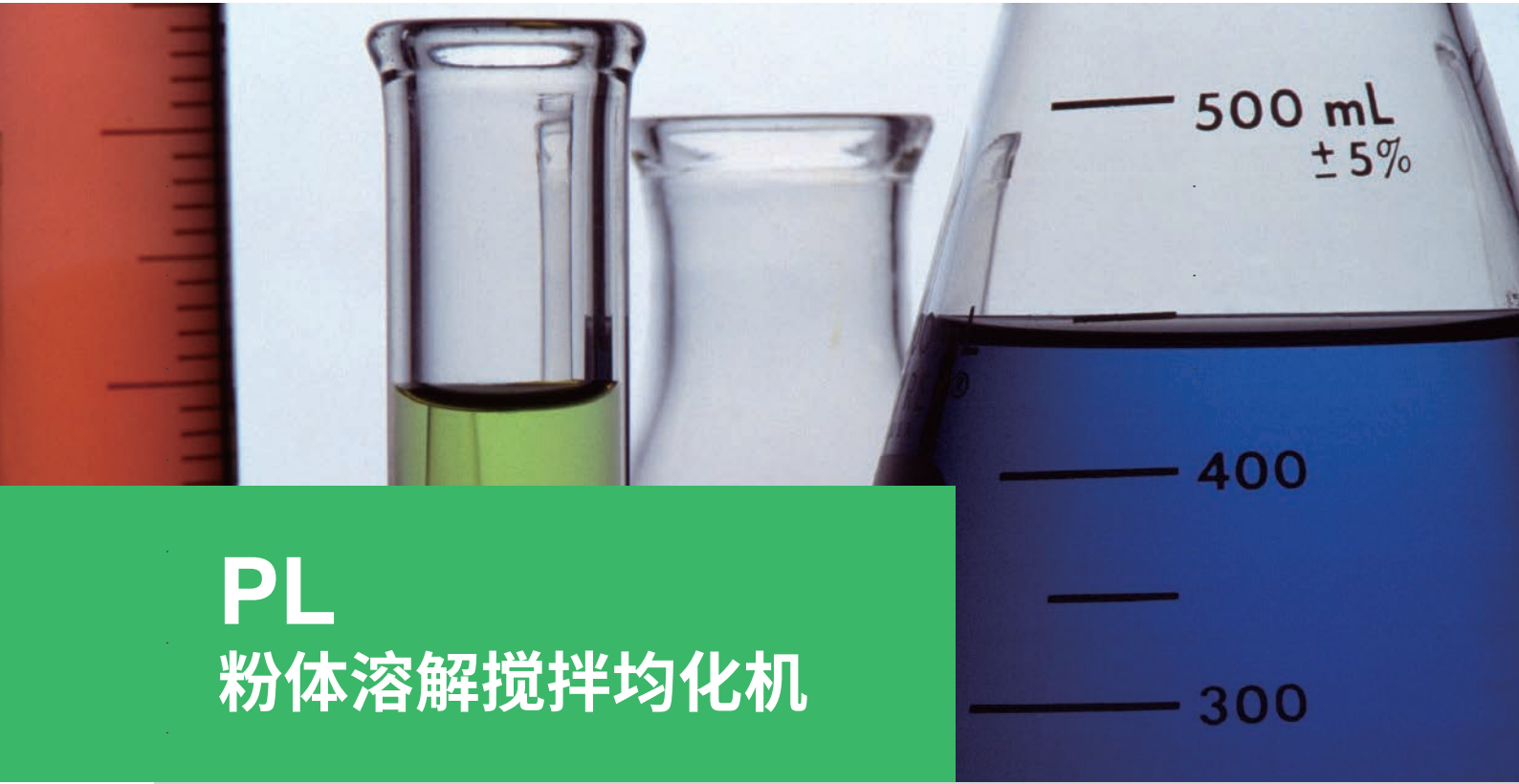

川源(中国)机械有限公司
GSD (China) Co., Ltd.



PL 粉体溶解搅拌均化机

PL automatic dispensing dissolvers



PL 粉体溶解搅拌均化机

PL automatic dispensing dissolvers

特点

- 三槽一体(混合槽、调匀槽、储存槽)连续式泡制,操作保养简易,可降低人力成本。(限PL3机型)
- PL1机型可依实际需求增添溶液储存供料桶(槽),可以扩充为双槽式使用,使泡制功能更连续自动化。
- 机台具有粉状或液态(选配备)双重进料功能设计,可满足不同之需求。
- 机台具比例调配功能,可依实际需求任意调整泡制所需药液浓度。
- 本机台泡制浓度均匀适中,可减少因人工调配不当造成结粒(块)现象阻塞管路或泵浦,避免增加不必要人员维护费用及药粉支出费用。
- 药粉供料槽具有抗凝结加热保温功能,可避免药粉受潮结块或变质情形发生。
- 药粉进料器独具液晶转速显示装置,使药粉进料量与泡制浓度更加精准掌控。(限PL3机型)
- 药、液混合器荣获新型专利产品设计,融合效果达到100%,独特的创新功能品质保证。(专利号: ZL201620737841.5 专利种类: 实用新型)
- 机台设计独具待机时间,可自动间歇及停顿交叉搅拌功能,使泡制溶液融合效果均匀,永远保持在较佳使用状态。(限PL3机型)
- 当药粉供料槽至低存量时,感应侦测器具灯号警示及机台停车之功能辅助,对机台整体操控性更加完美。(选配备)
- 适用于泡制药液浓度0.05~0.25%,若需要泡制药液浓度超过0.25%,请另询。

Features

- 3 tanks (Mixing Tank, Equalization Tank, Storage Tank) are integrated in single machine; dissolving sequences are continuously proceeded. Easily operated and maintained. Save labor cost to the minimum. (Type PL3).
- PL1 is designed to be flexible of adding extra Solution Storage/Feeding Tank, the machine can become a 2-tank machine, the dissolving sequences can be automatized and become continuous.
- An optional Liquid Feeding System provides more flexible choice for the states of raw material supplying.
- Proportion of the powder and water could be regulated freely, desired concentration of solution can be easily procured.
- The concentration of solution is uniformly controlled; failure owing to manual dosing could be eliminated, flocks will never occur. The pipeline and pump won't be clogged, waste of powder and unnecessary maintenance won't happen.
- Powder Feeding Hopper is equipped with Anti-condensation Heater, the agglomeration of the powder could be prevented. Also the temperature of powder could be kept, the powder transformation won't happen.
- Rotation speeds of the Powder Stoker are indicated by LED display, powder feeding amount and concentration of the solution can be more precisely monitored. (Type PL3)
- Patented Powder/Water Mixer makes perfect dissolution, the outstanding design guarantee 100% solution production.(Patent number:ZL201620737841.5 Patents Type:utility model)
- Machine equipped with Stand-By mode, it provides intermitted mixing functions, when the machine is in Stand-By mode waiting for next preparation, the agitators can be actuated at set intervals and working at set times. This function will keep the prepared solution, which is ready for use and kept in the machine, always in fully equivalent condition, so that the solution can be in nice condition for use. (Type PL3)
- When the powder Feeding Hopper is at lower level, the alarm will alert and the machine will be automatically stopped. Which makes the machine more energy-saving and saving labor attendance. (Optional Equipment)
- Suitable for 0.05~0.25% concentration of solution. If more than 0.25% concentration is needed, please inquire.

PL1 结构分布图 Structural Schema For PL1 Series

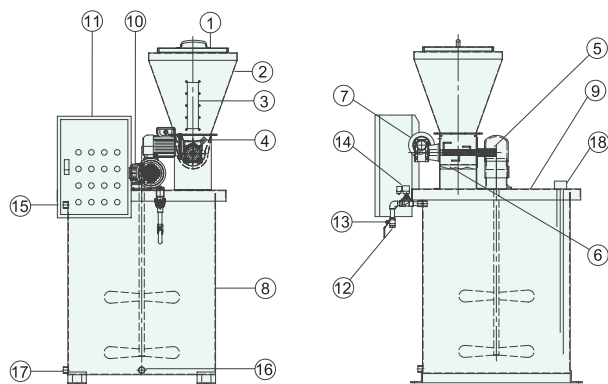

NO.	名称	NAME
1	药粉供料槽盖板	Powder feeding hopper lid
2	药粉供料槽	Powder feeding hopper
3	药粉透视窗	Powder monitoring window
4	药粉感应侦测器(选配备)	Powder level sensor(optional equipment)
5	药粉进料器	Powder stoker
6	电热器	Heater
7	药粉输送机	Powder metering feeder
8	混合搅拌供料槽	Mixing/feeding tank
9	混合搅拌供料槽盖板	Mixing/feeding tank lid
10	药液搅拌机	Chemical solution agitator
11	电控箱	Control panel
12	进水口	Water inlet
13	球塞凡而	Ball valve
14	电动球塞阀	Electric ball valve
15	溢流口	Overflow hole
16	排放口=1孔	Drainage hole(1 hole)
17	药液出口(至药液加药泵)	Chemical solution outlet(to dosing pump)
18	液位控制计	Level sensor

PL2 结构分布图 Structural schema for PL2 series

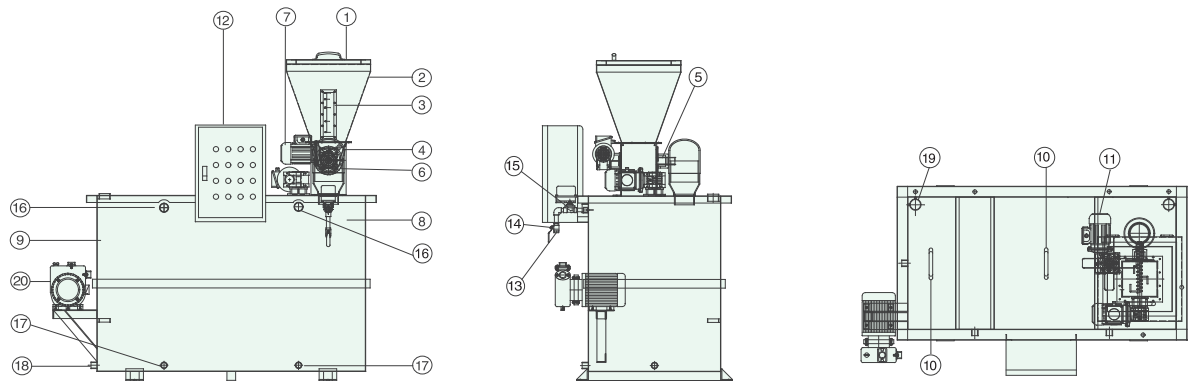

NO.	名称	NAME
1	药粉供料槽盖板	Powder feeding hopper lid
2	药粉供料槽	Powder feeding hopper
3	药粉透视窗	Powder monitoring window
4	药粉感应侦测器(选配备)	Powder level sensor (optional equipment)
5	药粉进料器	Powder stoker
6	电热器	Heater
7	药粉输送机	Powder metering feeder
8	混合搅拌槽	Mixing/agitating tank
9	熟化储存槽	Equalization tank
10	混合、熟化槽盖板	Mixing/equalization tank lid

NO.	名称	NAME
11	药液搅拌机=1台	Chemical solution agitator (1 set)
12	电控箱	Control panel
13	进水口	Water inlet
14	球塞凡而	Ball valve
15	电动球塞阀	Electric ball valve
16	溢流口=2孔	Overflow hole (2 holes)
17	排放口=2孔	Drainage hole (2 holes)
18	药液出口(至药液加药泵)	Chemical solution outlet (to dosing pump)
19	液位控制计	Level sensor
20	药液移送泵	Transferring pump

PL3 结构分布图 Structural schema for PL3 series

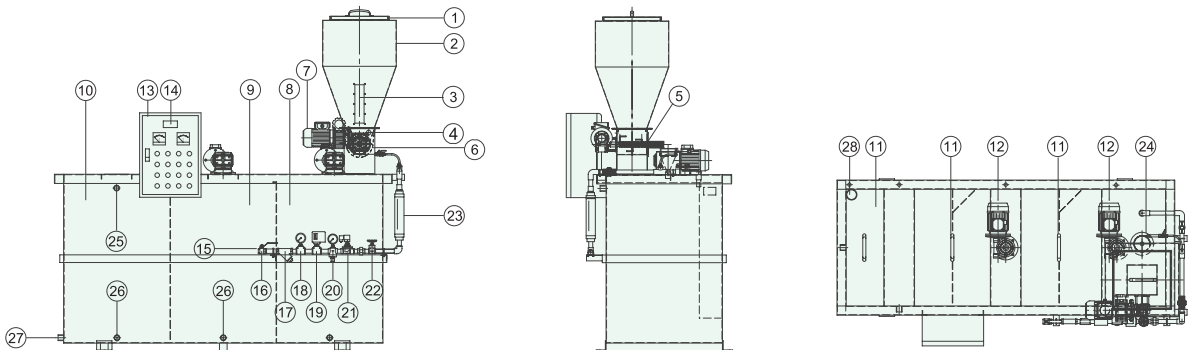

NO.	名称	NAME
1	药粉供料槽盖板	Powder feeding hopper lid
2	药粉供料槽	Powder feeding hopper
3	药粉透视窗	Powder monitoring window
4	药粉感应侦测器(选配备)	Powder level sensor(optional equipment)
5	药粉进料器	Powder stoker
6	电热器	Heater
7	药粉输送机	Powder metering feeder
8	混合搅拌槽	Mixing/agitating tank
9	调匀熟化槽	Equalization tank
10	药液储存供料槽	Chemical solution storage/feeding tank
11	混合、调匀、储存槽盖板	Lids of tanks
12	药液搅拌机=2台	Chemical solution agitator(2 sets)
13	电控箱	Control panel
14	药粉输送机液晶转速显示器	Powder metering feeder speed LCD indicator

NO.	名称	NAME
15	进水口	Water inlet
16	球塞凡而	Ball valve
17	Y型过滤器	Y strainer
18	压力计	Pressure gauge
19	压力设定控制开关	Pressure setting switch
20	压力调整阀	Pressure regulator
21	电动球塞阀	Electric ball valve
22	流量调整阀	Flow regulator
23	流量计	Flow meter
24	药、液混合器	Mixer
25	溢流口	Overflow hole
26	排放口=3孔	Drainage hole(3 holes)
27	药液出口(至药液加药泵)	Chemical solution outlet(to dosing pump)
28	液位控制计	Level sensor



PL1 性能规格配备及尺寸表

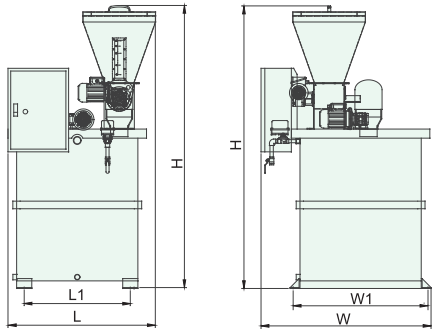

PL1 Type technical data

机型 Model	构造 型式 Machine Structure	药液 泡制量 Chemical Solution Production Capacity (L/h)	药粉 供料槽 容量 Powder Feeding Hopper Volume (L)	药粉 输送机 (定速) Powder Metering Feeder (Fixedspeed) (hp)	药液 搅拌机 Chemical Solution Agitator (hp)	槽体材质 Material of Tanks		机械尺寸 Machine Dimensions (mm)					重量 Weight (kg)
						标准 Standard	特殊指定 Optional	长 (L)	宽 (W)	高 (H)	L1	W1	
PL1-500	单槽 批次式 Single- tank Batch type	500	55	1/4	1/2	SUS304 (不锈钢)	SUS316 (不锈钢)	1010	1150	1870	700	890	200
PL1-1000		1000	55	1/4	3/4		P.P (聚丙烯)	1200	1350	2000	900	1090	270
PL1-1500		1500	55	1/4	1		P.V.C (聚氯乙烯)	1400	1550	2070	1100	1290	360
PL1-2000		2000	110	1/4	1		F.R.P (玻璃钢)	1500	1650	2260	1200	1390	470

PL2 性能规格配备及尺寸表

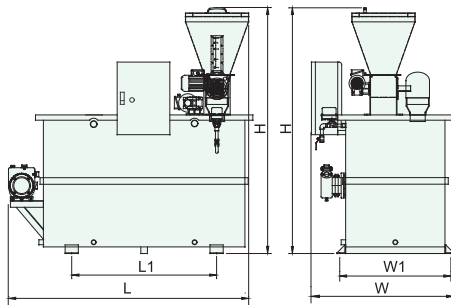

PL2 Type technical data

机型 Model	构造 型式 Machine Structure	药液 泡制量 Chemical Solution Production Capacity (L/h)	药粉 供料槽 容量 Powder Feeding Hopper Volume (L)	药粉 输送机 (定速) Powder Metering Feeder (Fixedspeed) (hp)	药液 搅拌机 Chemical Solution Agitator (hp)	槽体材质 Material of Tanks		机械尺寸 Machine Dimensions (mm)					重量 Weight (kg)
						标准 Standard	特殊指定 Optional	长 (L)	宽 (W)	高 (H)	L1	W1	
PL2-500	二槽 连续式 2 tanks Continu- ous type	500	55	1/4	1/2	SUS304 (不锈钢)	SUS316 (不锈钢)	1950	1096	1870	1100	840	270
PL2-1000		1000	55	1/4	3/4		P.P (聚丙烯)	2250	1280	2070	1400	1050	390
PL2-1500		1500	55	1/4	1		P.V.C (聚氯乙烯)	2710	1500	2070	1800	1250	470
PL2-2000		2000	110	1/4	1		F.R.P (玻璃钢)	2820	1550	2300	1800	1300	580

PL3 性能规格配备及尺寸表

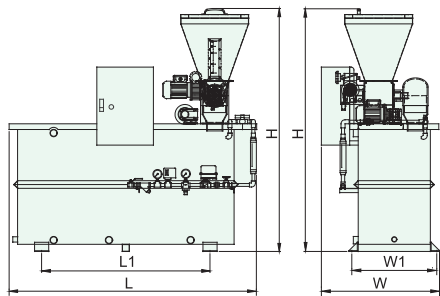

PL3 Type technical data

机型 Model	构造 型式 Machine Structure	药液 泡制量 Chemical Solution Production Capacity (L/h)	药粉 供料槽 容量 Powder Feeding Hopper Volume (L)	药粉 输送机 (定速) Powder Metering Feeder (Fixedspeed) (hp)	药液 搅拌机 Chemical Solution Agitator (hp)	槽体材质 Material of Tanks		机械尺寸 Machine Dimensions (mm)					重量 Weight (kg)
						标准 Standard	特殊指定 Optional	长 (L)	宽 (W)	高 (H)	L1	W1	
PL3-500	三槽 连续式 3 tanks Continu- ous type	500	55	1/4	1/4x2	SUS304 (不锈钢)	SUS316 (不锈钢) P.P (聚丙烯) P.V.C (聚氯乙烯) F.R.P (玻璃钢)	1750	840	1720	1190	600	300
PL3-1000		1000	55	1/4	1/2x2			2020	940	1970	1380	700	430
PL3-1500		1500	55	1/4	1/2x2			2280	1100	1970	1550	860	520
PL3-2000		2000	110	1/4	3/4 x 2			2670	1130	2100	1910	890	550
PL3-3000		3000	110	1/4	1x2			3140	1310	2100	2320	1080	700
PL3-5000		5000	200	1/4	1x2			3230	1620	2570	2350	1390	990
PL3-7000		7000	200	1/4	2x2			4070	1760	2570	3130	1500	1100
PL3-10000		10000	350	1/4	3x2			4780	1850	3035	3840	1600	1430

免费咨询电话

400-657-9066

本型录内容如有变更，恕不另行通知。

We reserve the right to change content without notice.

川源(中国)机械有限公司版权所有 all rights reserved. CY-16

