



川源(中国)机械有限公司
GSD (China) Co., Ltd.

RSV 真空风机

RSV vacuum roots blower



RSV 真空风机

RSV vacuum roots blower

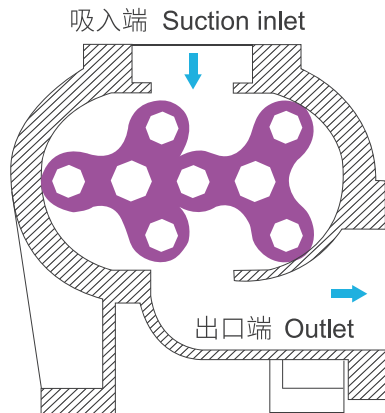

原理 Theory

RSV 真空风机是一种容积式风机，其负压可根据用户的要求在允许的范围内加以调节，在机壳内部设置有两组互朝相反方向回传的叶轮，在叶轮与叶轮，及叶轮与壳体间仅留极小缝隙的状态下回转。当叶轮经过吸入端时，与壳体之间捕捉一定量的空气，随叶轮的旋转，空气侧移，从出口端排出。在运转过程中，吸入端管路的负压会慢慢升高，直至要求值。

RSV vacuum roots blower is a positive displacement blower, the negative pressure of which can be adjusted within the allowed range according to the requirements of users. Two groups of impellers rotating in opposite directions are arranged inside the blower shell, and rotate when the gap between the impellers as well as between the impeller and the shell is rather small. When the impellers pass through the suction end, certain air is held between the impellers and the shell. With the rotation of the impellers, the air moves aside to be exhausted from the exit end. During the operation, the negative pressure in the pipeline at the suction end will increase slowly till to the required value.

特点

- 风量和压力范围大。
口径：40mm~300mm
风量：0.67~181m³/min
真空压力：-1000mmAq~ -6000mmAq
- 电脑动平衡校正，低振动低噪音。
- 风量稳定，压力变化对风量之影响小。
- 特殊叶轮设计，高效率省能源。
- 构造简单坚固，无故障。
- 使用一级研磨齿轮，精度高，寿命长，低噪音。
- 严格品质管理，标准化制品。
- 叶轮采用最新之龙门刨床六轴加工法，一次加工完成，使更换方便，其具有更高之精密度。

Features

- Wide range of capacity and pressure.
Calibre: 40mm~300mm
Capacity: 0.67~181m³/min
Vacuum pressure: -1000mmAq~ -6000mmAq
- Low oscillation and low noise by dynamic balance which revised by computer.
- Smaller change in capacity against change in pressure.
- High efficiency due to special impeller design, great air-delivery low power.
- Simpler and solider structure, less trouble. Highest quality pilot & accurate great applied, long life and low noise assured.
- Standardized product with strict quality control. Our rotor has used the most advanced technic, one time for all working process of the six-shaft method, to enhance the precision.

型号说明 Type description

RSV - 50

└───┬───┘ 口径 Diameter(mm)
└───┘ RSV真空风机 RSV vacuum roots blower

外形结构图 Externality construction

NO.	名称	Name
1	主机	Blower body
2	底座	Foundation
3	电机	Motor
4	皮带	Belt
5	泄压阀	Release valve
6	皮带护罩	Belt cover
7	真空过滤桶	Vacuum filter vat
8	负压表	Negative pressure gauge
9	出口消音器	Outlet silencer
10	弯头	Elbow

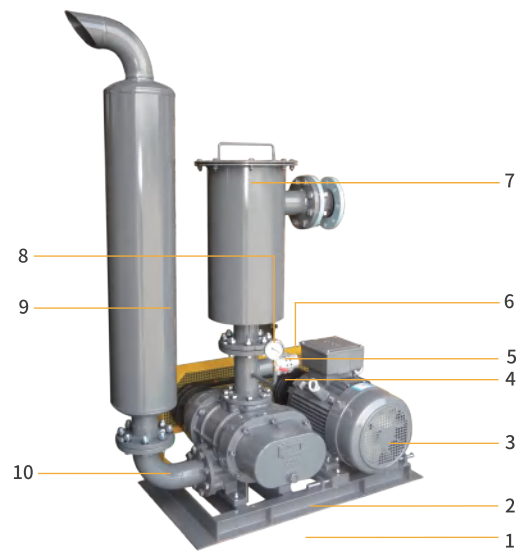

结构简图 Construction

NO.	名称	Name	材质 Material	
			GB	JIS
1	鼓风机本体	Casing	HT250	FC250
2	轴承座	Bearing housing	HT250	FC250
3	油箱	Oil box	HT250	FC250
4	甩油片	Oil splash	Q235	SS400
5	轴承固定片	Bearing washer	Q235	SS400
6	骨架油封	Framework oil seal	NBR	NBR
7	皮带轮	Pulley	HT250	FC250
8	主动叶轮	Drive rotor	HT250	FC250
9	被动叶轮	Driven rotor	HT250	FC250
10	V型油封	V-ring	NBR	NBR
11	轴承	Bearing	GCr15	SUJ2
12	齿轮	Gear	20GrMnTi	SCM415
13	止动垫圈	Lock washer	Q235	SS400
14	止动螺母	Lock nut	45	S45C
15	齿轮箱	Gear box	HT250	FC250
16	加油柱塞	Lubrication plug	45	S45C
17	润滑油面计	Oil gauge	Assembly	Assembly
18	泄油柱塞	Purge plug	45	S45C

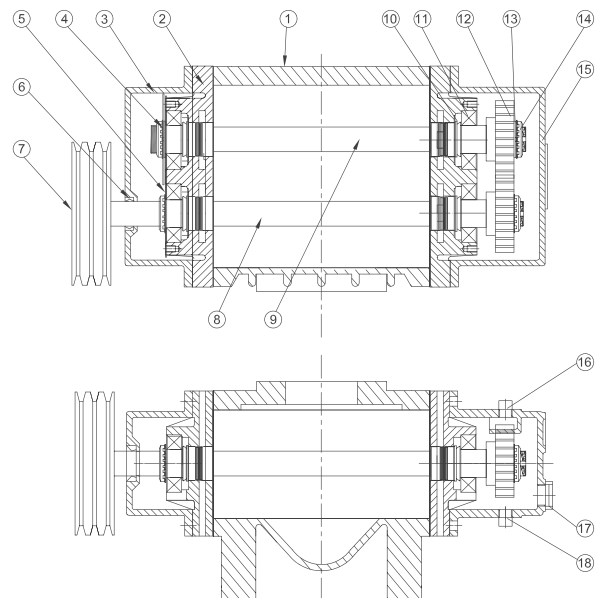

注：不同机型结构略有不同。
 Note: Different model has a little difference.



单位换算表 Conversion table

Pressure	atm	kPa	bar	lbt/in ² (psi)	kgf/cm ²	in Hg	ftAq	mmHg(Torr)	mmAq
1 atm	1	101.325	1.01325	14.696	1.0333	29.921	33.914	760	10333
1 kPa	0.0099	1	0.01	0.145	0.0102	0.295	0.335	7.5	102
1 bar	0.9869	100	1	14.504	1.0198	29.53	33.47	750	10198
1 lbt/in ² (psi)	0.068	6.894	0.0689	1	0.0703	2.036	2.308	51.71	703
1 kgf/cm ²	0.968	98.062	0.981	14.228	1	28.96	32.82	735.53	10000
1 inHg	0.0334	3.3863	0.0339	0.491	0.0345	1	1.133	25.4	345.3
1 ftAq	0.0295	2.99	0.0299	0.434	0.0305	0.882	1	22.42	304.8
1 mmHg(Torr)	0.013	0.1338	0.00138	0.019	0.0014	0.04	0.045	1	13.6
1 mmAq	0.000097	0.0098	0.000098	0.0014	0.0001	0.003	0.0033	0.074	1

Capacity	m ³ /min	l/min	cm ³ /s	in ³ /s	ft ³ /min(cfm)
1 m ³ /min	1	1000	16667	1016	35.288
1 l/min	0.001	1	16.67	1.02	0.0353
1 cm ³ /s	0.00006	0.06	1	0.06	0.002
1 in ³ /s	0.00098	0.983	16.39	1	0.035
1 ft ³ /min(cfm)	0.028	28.32	471.95	28.8	1

压力常用换算公式

Pressure Conversion Formula

1 kPa=1000Pa=1000N/m²

1mbar=10.198mmAq

1mmHg(Torr)=133.8Pa

性能参数 Performance parameters

型号 Type	转速 RPM	Qs (m ³ /min) Pressure (mmAq) La (kW)											
		-1000mmAq		-2000mmAq		-3000mmAq		-4000mmAq		-5000mmAq		-6000mmAq	
		Qs	La	Qs	La	Qs	La	Qs	La	Qs	La	Qs	La
RSV-40	1050	1.32	0.52	1.15	0.79	1.00	1.06	0.85	1.32	0.67	1.59	-	-
	1150	1.47	0.57	1.31	0.86	1.16	1.16	1.00	1.45	0.83	1.74	-	-
	1250	1.63	0.62	1.47	0.94	1.31	1.26	1.16	1.58	0.98	1.90	-	-
	1350	1.79	0.67	1.62	1.01	1.47	1.36	1.32	1.70	1.14	2.05	-	-
	1450	1.94	0.71	1.78	1.09	1.63	1.46	1.47	1.83	1.30	2.20	1.09	2.57
	1550	2.10	0.76	1.94	1.16	1.79	1.56	1.63	1.95	1.45	2.35	1.24	2.75
	1650	2.26	0.81	2.09	1.24	1.94	1.66	1.79	2.08	1.61	2.50	1.40	2.93
	1750	2.41	0.86	2.25	1.31	2.10	1.76	1.94	2.21	1.77	2.65	1.56	3.10
	1850	2.57	0.91	2.41	1.39	2.26	1.86	2.10	2.33	1.92	2.81	1.71	3.28
1950	2.73	0.96	2.56	1.46	2.41	1.96	2.26	2.46	2.08	2.96	1.87	3.46	
RSV-50	1050	2.31	0.75	2.10	1.20	1.91	1.65	1.70	2.10	1.48	2.55	1.20	2.99
	1150	2.58	0.82	2.36	1.32	2.17	1.81	1.96	2.30	1.74	2.79	1.46	3.28
	1250	2.84	0.90	2.62	1.43	2.43	1.96	2.23	2.50	2.00	3.03	1.73	3.56
	1350	3.10	0.97	2.89	1.54	2.69	2.12	2.49	2.70	2.26	3.27	1.99	3.85
	1450	3.36	1.04	3.15	1.66	2.95	2.28	2.75	2.90	2.52	3.51	2.25	4.13
	1550	3.62	1.11	3.41	1.77	3.21	2.43	3.01	3.10	2.78	3.76	2.51	4.42



性能参数 Performance parameters

Qs (m³/min) Pressure (mmAq) La (kW)

型号 Type	转速 RPM	-1000mmAq		-2000mmAq		-3000mmAq		-4000mmAq		-5000mmAq		-6000mmAq	
		Qs	La	Qs	La	Qs	La	Qs	La	Qs	La	Qs	La
RSV-50	1650	3.88	1.18	3.67	1.89	3.47	2.59	3.27	3.30	3.04	4.00	2.77	4.70
	1750	4.14	1.26	3.93	2.00	3.73	2.75	3.53	3.50	3.30	4.24	3.03	4.99
	1850	4.40	1.33	4.19	2.12	4.00	2.91	3.79	3.70	3.57	4.48	3.29	5.27
	1950	4.67	1.40	4.45	2.23	4.26	3.06	4.05	3.89	3.83	4.73	3.55	5.56
RSV-65	1050	3.03	0.97	2.76	1.46	2.51	2.05	2.26	2.63	1.97	3.21	1.63	3.79
	1150	3.37	1.06	3.10	1.60	2.85	2.24	2.60	2.88	2.31	3.52	1.97	4.15
	1250	3.71	1.16	3.44	1.74	3.19	2.44	2.94	3.13	2.65	3.82	2.31	4.52
	1350	4.05	1.25	3.78	1.88	3.53	2.63	3.28	3.38	2.99	4.13	2.65	4.88
	1450	4.39	1.34	4.12	2.02	3.87	2.83	3.62	3.63	3.33	4.43	2.99	5.24
	1550	4.73	1.43	4.46	2.16	4.21	3.02	3.96	3.88	3.67	4.74	3.33	5.60
	1650	5.07	1.53	4.80	2.30	4.55	3.22	4.30	4.13	4.01	5.05	3.67	5.96
	1750	5.41	1.62	5.14	2.44	4.89	3.41	4.64	4.38	4.35	5.35	4.01	6.32
RSV-80	1000	5.28	1.63	4.92	2.61	4.60	3.59	4.26	4.57	3.88	5.55	3.43	6.52
	1100	5.88	1.79	5.52	2.87	5.20	3.95	4.86	5.02	4.48	6.10	4.02	7.18
	1200	6.48	1.96	6.12	3.13	5.79	4.31	5.46	5.48	5.08	6.65	4.62	7.83
	1300	7.07	2.12	6.72	3.39	6.39	4.66	6.06	5.94	5.68	7.21	5.22	8.48
	1400	7.67	2.28	7.32	3.65	6.99	5.02	6.65	6.39	6.28	7.76	5.82	9.13
	1500	8.27	2.45	7.92	3.91	7.59	5.38	7.25	6.85	6.88	8.32	6.42	9.79
	1600	8.87	2.61	8.52	4.18	8.19	5.74	7.85	7.31	7.47	8.87	7.02	10.44
	1650	9.17	2.69	8.82	4.31	8.49	5.92	8.15	7.54	7.77	9.15	7.32	10.76
	1750	9.77	2.85	9.42	4.57	9.09	6.28	8.75	7.99	8.37	9.70	7.92	11.42
	1850	10.37	3.02	10.02	4.83	9.69	6.64	9.35	8.45	8.97	10.26	8.52	12.07
RSV-100	1000	7.40	2.47	6.92	3.84	6.47	5.21	6.00	6.58	5.48	7.95	4.85	9.32
	1100	8.24	2.72	7.75	4.22	7.31	5.73	6.84	7.24	6.32	8.74	5.69	10.25
	1200	9.08	2.96	8.59	4.61	8.14	6.25	7.68	7.90	7.16	9.54	6.53	11.18
	1300	9.92	3.21	9.43	4.99	8.98	6.77	8.52	8.55	8.00	10.33	7.37	12.12
	1400	10.76	3.46	10.27	5.37	9.82	7.29	9.36	9.21	8.83	11.13	8.21	13.05
	1500	11.60	3.70	11.11	5.76	10.66	7.81	10.19	9.87	9.67	11.92	9.05	13.98
	1600	12.44	3.95	11.95	6.14	11.50	8.33	11.03	10.53	10.51	12.72	9.89	14.91
	1650	12.86	4.07	12.37	6.33	11.92	8.60	11.45	10.86	10.93	13.12	10.31	15.38
	1750	13.70	4.32	13.21	6.72	12.76	9.12	12.29	11.51	11.77	13.91	11.14	16.31
	1850	14.53	4.57	14.05	7.10	13.60	9.64	13.13	12.17	12.61	14.71	11.98	17.24
RSV-125A	990	11.12	3.31	10.59	5.30	10.11	7.29	9.61	9.28	9.05	11.27	7.13	13.25
	1050	11.85	3.51	11.33	5.62	10.84	7.73	10.34	9.84	9.78	11.95	7.74	14.06
	1110	12.59	3.72	12.07	5.94	11.58	8.17	11.08	10.40	10.52	12.63	8.36	14.86
	1180	13.45	3.95	12.93	6.32	12.44	8.69	11.94	11.06	11.38	13.43	8.97	15.80
	1250	14.31	4.18	13.79	6.69	13.30	9.20	12.80	11.71	12.24	14.23	9.71	16.74
	1320	15.17	4.42	14.65	7.07	14.16	9.72	13.66	12.37	13.10	15.02	10.45	17.67
	1390	16.03	4.65	15.51	7.44	15.02	10.24	14.52	13.03	13.96	15.82	11.19	18.61
	1470	17.02	4.92	16.49	7.87	16.01	10.82	15.51	13.78	14.95	16.73	12.05	19.68
	1560	18.12	5.22	17.60	8.35	17.11	11.49	16.61	14.62	16.05	17.75	12.91	20.89
	1650	19.23	5.52	18.71	8.84	18.22	12.15	17.72	15.46	17.16	18.78	13.77	22.09
1750	20.46	5.86	19.93	9.37	19.45	12.89	18.95	16.40	18.39	19.92	14.63	23.43	
1850	21.69	6.19	21.16	9.91	20.68	13.62	20.18	17.34	19.62	21.05	15.61	24.77	



性能参数 Performance parameters

Qs (m³/min) Pressure (mmAq) La (kW)

型号 Type	转速 RPM	-1000mmAq		-2000mmAq		-3000mmAq		-4000mmAq		-5000mmAq		-6000mmAq	
		Qs	La	Qs	La	Qs	La	Qs	La	Qs	La	Qs	La
RSV-125	990	16.35	4.84	15.63	7.75	14.97	10.65	14.29	13.56	13.52	16.47	12.60	19.37
	1050	17.43	5.14	16.71	8.22	16.05	11.30	15.36	14.38	14.60	17.46	13.68	20.55
	1110	18.50	5.43	17.79	8.69	17.13	11.95	16.44	15.20	15.68	18.46	14.76	21.72
	1180	19.76	5.77	19.04	9.24	18.38	12.70	17.70	16.16	16.93	19.63	16.02	23.09
	1250	21.02	6.11	20.30	9.78	19.64	13.45	18.96	17.12	18.19	20.79	17.27	24.46
	1320	22.28	6.46	21.56	10.33	20.90	14.21	20.22	18.08	19.45	21.96	18.53	25.83
	1390	23.53	6.80	22.82	10.88	22.16	14.96	21.47	19.04	20.71	23.12	19.79	27.20
	1470	24.97	7.19	24.26	11.51	23.60	15.82	22.91	20.14	22.15	24.45	21.23	28.76
	1560	26.59	7.63	25.87	12.21	25.21	16.79	24.53	21.37	23.76	25.95	22.85	30.53
	1650	28.21	8.07	27.49	12.91	26.83	17.76	26.15	22.60	25.38	27.44	24.46	32.29
	1750	30.00	8.56	29.29	13.70	28.63	18.83	27.94	23.97	27.18	29.11	26.26	34.24
1850	31.80	9.05	31.08	14.48	30.42	19.91	29.74	25.34	28.98	30.77	28.06	36.20	
RSV-150	990	21.13	6.24	20.22	9.99	19.39	13.74	18.53	17.49	17.57	21.23	16.42	24.98
	1050	22.52	6.62	21.61	10.60	20.78	14.57	19.93	18.55	18.96	22.52	17.81	26.49
	1110	23.91	7.00	23.01	11.20	22.18	15.40	21.32	19.61	20.35	23.81	19.20	28.01
	1180	25.53	7.44	24.63	11.91	23.80	16.38	22.94	20.84	21.98	25.31	20.82	29.77
	1250	27.15	7.89	26.25	12.62	25.42	17.35	24.56	22.08	23.60	26.81	22.44	31.54
	1320	28.77	8.33	27.87	13.32	27.04	18.32	26.18	23.31	25.22	28.31	24.07	33.31
	1390	30.39	8.77	29.49	14.03	28.66	19.29	27.80	24.55	26.84	29.81	25.69	35.07
	1470	32.25	9.27	31.35	14.84	30.52	20.40	29.66	25.96	28.70	31.53	27.54	37.09
	1560	34.33	9.84	33.43	15.74	32.60	21.65	31.74	27.55	30.78	33.46	29.63	39.36
	1650	36.42	10.41	35.52	16.65	34.69	22.90	33.83	29.14	32.87	35.39	31.71	41.63
	1750	38.74	11.04	37.84	17.66	37.01	24.29	36.15	30.91	35.18	37.53	34.03	44.16
1850	41.05	11.67	40.15	18.67	39.32	25.67	38.46	32.68	37.50	39.68	36.35	46.68	
RSV-200A	990	34.49	10.02	33.35	16.03	32.30	22.04	31.21	28.05	29.99	34.06	28.52	40.07
	1050	36.72	10.62	35.58	17.00	34.53	23.37	33.44	29.75	32.22	36.12	30.75	42.50
	1110	38.95	11.23	37.81	17.97	36.76	24.71	35.67	31.45	34.45	38.19	32.98	44.92
	1180	41.56	11.94	40.41	19.10	39.36	26.27	38.27	33.43	37.05	40.59	35.58	47.76
	1250	44.16	12.65	43.01	20.24	41.96	27.82	40.87	35.41	39.65	43.00	38.18	50.59
	1320	46.76	13.36	45.62	21.37	44.56	29.38	43.47	37.40	42.25	45.41	40.79	53.42
	1390	49.36	14.06	48.22	22.50	47.16	30.94	46.07	39.38	44.85	47.82	43.39	56.26
	1470	52.34	14.87	51.19	23.80	50.14	32.72	49.05	41.65	47.83	50.57	46.36	59.49
RSV-200	990	44.73	12.88	43.46	20.61	42.28	28.33	41.06	36.06	39.69	43.79	38.05	51.52
	1050	47.60	13.66	46.32	21.86	45.15	30.05	43.93	38.25	42.56	46.44	40.92	54.64
	1110	50.47	14.44	49.19	23.10	48.01	31.77	46.79	40.43	45.43	49.10	43.79	57.76
	1180	53.81	15.35	52.54	24.56	51.36	33.77	50.14	42.98	48.77	52.19	47.13	61.40
	1250	57.16	16.26	55.88	26.02	54.70	35.77	53.48	45.53	52.12	55.29	50.48	65.05
	1320	60.50	17.17	59.23	27.48	58.05	37.78	56.83	48.08	55.46	58.38	53.83	68.69
	1390	63.85	18.08	62.57	28.93	61.39	39.78	60.17	50.63	58.81	61.48	57.17	72.33
	1470	67.67	19.12	66.39	30.60	65.22	42.07	64.00	53.55	62.63	65.02	60.99	76.49
RSV-250	990	60.07	17.17	58.57	27.48	57.19	37.78	55.76	48.08	54.16	58.38	52.24	68.69
	1050	63.89	18.21	62.39	29.14	61.01	40.07	59.58	51.00	57.99	61.92	56.07	72.85
	1110	67.71	19.25	66.21	30.81	64.84	42.36	63.41	53.91	61.81	65.46	59.89	77.01
	1180	72.17	20.47	70.67	32.75	69.30	45.03	67.87	57.31	66.27	69.59	64.35	81.87
	1250	76.63	21.68	75.13	34.69	73.76	47.70	72.33	60.71	70.73	73.72	68.81	86.73
	1320	81.09	22.90	79.59	36.63	78.22	50.37	76.79	64.11	75.19	77.85	73.27	91.58
	1390	85.55	24.11	84.05	38.58	82.68	53.04	81.25	67.51	79.65	81.97	77.73	96.44
	1470	90.65	25.50	89.15	40.80	87.77	56.10	86.35	71.39	84.75	86.69	82.83	101.99

性能参数 Performance parameters

Qs (m³/min) Pressure (mmAq) La (kW)

型号 Type	转速 RPM	-1000mmAq		-2000mmAq		-3000mmAq		-4000mmAq		-5000mmAq		-6000mmAq	
		Qs	La	Qs	La	Qs	La	Qs	La	Qs	La	Qs	La
RSV-300A	990	79.90	22.90	77.81	36.63	75.89	50.37	73.90	64.11	71.67	77.85	68.99	91.58
	1050	85.00	24.28	82.91	38.85	80.99	53.42	78.99	67.99	76.76	82.56	74.09	97.13
	1110	90.10	25.67	88.01	41.07	86.08	56.48	84.09	71.88	81.86	87.28	79.19	102.68
	1180	96.04	27.29	93.95	43.66	92.03	60.04	90.04	76.41	87.81	92.79	85.13	109.16
	1250	101.99	28.91	99.90	46.25	97.98	63.60	95.98	80.95	93.76	98.29	91.08	115.64
	1320	107.94	30.53	105.85	48.84	103.92	67.16	101.93	85.48	99.70	103.79	97.03	122.11
	1390	113.88	32.15	111.79	51.43	109.87	70.72	107.88	90.01	105.65	109.30	102.97	128.59
	1470	120.68	34.00	118.59	54.40	116.67	74.79	114.68	95.19	112.45	115.59	109.77	135.99
RSV-300	800	100.98	29.11	98.02	46.58	95.29	64.05	92.46	81.52	89.30	98.99	85.50	116.46
	900	114.35	32.75	111.38	52.40	108.66	72.06	105.83	91.71	102.67	111.36	98.87	131.01
	1000	127.72	36.39	124.75	58.23	122.02	80.06	119.20	101.90	116.03	123.73	112.24	145.57
	1100	141.09	40.03	138.12	64.05	135.39	88.07	132.57	112.09	129.40	136.11	125.61	160.13
	1200	154.45	43.67	151.49	69.87	148.76	96.08	145.93	122.28	142.77	148.48	138.97	174.68
	1300	167.82	47.31	164.86	75.70	162.13	104.08	159.30	132.47	156.14	160.85	152.34	189.24
	1400	181.19	50.95	178.23	81.52	175.50	112.09	172.67	142.66	169.51	173.23	165.71	203.80

外形尺寸图 Installation dimensions

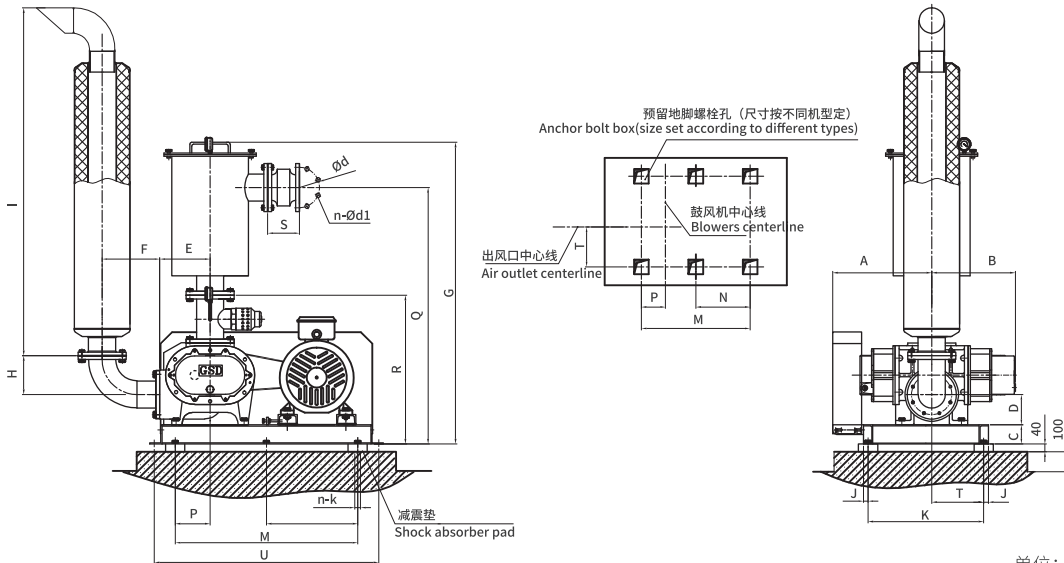

单位: Unit(mm)

型号 Type	A	B	C	D	E	F	G	H	I	J	K	M	N	U	Q	R	Ød	n-Ød1	P	T	S	n-k
RSV-40	235	230	56	104	140	200	1091	110	809.5	25	350	500	-	700	1011	541	125	4-Ø18	98	95	105	4-M12x160
RSV-50	300	270	80	103.5	140	200	1177	110	809.5	20	412	520	-	700	1041	571	125	4-Ø18	93	211	105	4-M12x160
RSV-65	323	300	80	104	152	200	1180	155	1303	20	412	520	-	700	1034	574	145	4-Ø18	93	188.5	115	4-M12x160
RSV-80	383	304	80	106.5	180	220	1316	168	1348.5	20	482	700	-	900	1121	621	160	8-Ø18	80	238	135	4-M12x160
RSV-100	426	354	80	110	180	250	1320	164	1396	20	482	700	-	900	1125	625	180	8-Ø18	98	195	150	4-M16x220
RSV-125A	495	376	100	135	250	300	1576	202	1811.5	24	602	950	-	1150	1340	780	210	8-Ø18	78	291	165	4-M16x220
RSV-125	515	436	100	157.5	262	300	1571	202	1811.5	24	602	950	-	1150	1335	775	210	8-Ø18	182	271	165	4-M16x220
RSV-150	574	490.5	100	163.5	250	320	1596	240	1863.5	24	602	950	-	1150	1360	800	240	8-Ø23	182	212	180	4-M16x220
RSV-200A	534	472	160	198	358	315	2041	315	2499.5	30	790	1300	650	-	1765	1085	295	8-Ø23	313	480.5	190	6-M20x300
RSV-200	584	522	160	194	345	315	2041	315	2499.5	30	940	1300	650	-	1765	1085	295	8-Ø23	310	580	190	6-M20x300
RSV-250	695	597	160	216	356	450	2146	421	2717.5	30	940	1400	700	-	1870	1120	350	12-Ø23	270	490	230	6-M20x300
RSV-300A	880	697	160	255	360	470	2378	470	2919.9	30	940	1500	750	-	2065	1135	400	12-Ø23	248	470	250	6-M20x300
RSV-300	797	627.5	250	300	510	470	2673	470	2919.5	35	1030	2000	1000	-	2360	1430	400	12-Ø23	321	487	250	6-M20x300

注: 当RSV-40配电机功率在1.1~4kW及以上, 风机底座尺寸另询。

Note: When the motor power of RSV-40 is 1.1-4kW or above, the size of the blower base should be specifically confirmed.



地脚螺栓 Anchor bolt

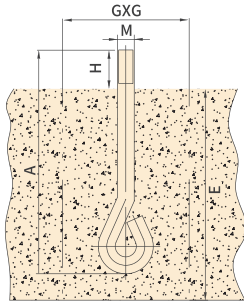

单位: Unit(mm)

地脚螺栓 M Anchor bolt GB799-88	A	H	E	G×G	适用型号 Application type
M12	160	36	224	100×100	RSV-40,50,65,80,100
M16	220	45	275	120×120	RSV-125A,125,150
M20	300	55	345	150×150	RSV-200A,200,250,300A,300

注: 1.图注E为最小尺寸, 根据安装的土壤情况, 应当适当加深。
2.GxG为二次浇灌前的预留孔尺寸。

Note: 1. The note E on the drawing is the minimum size, it shall be deepened properly according to the soil condition in the installation place.
2. GxG is the size of the preformed holes for the secondary casting.

出口消音器 Outlet silencer

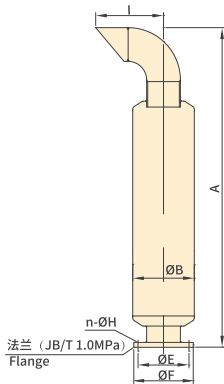

单位: Unit(mm)

型号 Type	A	B	E	F	n-ØH	l	重量 Weight (kg)	适用型号 Application type
DS50	809.5	159	125	160	4-Ø18	153	13	RSV-40, 50
DS65	1303	159	145	180	4-Ø18	190	22	RSV-65
DS80	1348.5	219	160	195	8-Ø18	223	31	RSV-80
DS100	1396	219	180	215	8-Ø18	280	34	RSV-100
DS125	1811.5	290	210	245	8-Ø18	343	58	RSV-125(A)
DS150	1863.5	290	240	280	8-Ø23	408	62	RSV-150
DS200	2499.5	356	295	335	8-Ø23	544	112	RSV-200(A)
DS250	2717.5	408	350	390	12-Ø23	674	168	RSV-250
DS300	2919.5	508	400	440	12-Ø23	802	220	RSV-300(A)

三通 "T"-joint

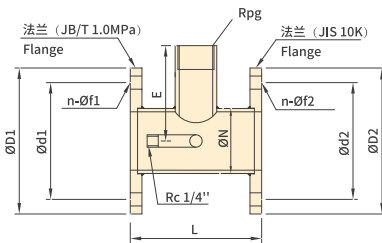

单位: Unit(mm)

型号 Type	N	L	E	D1	D2	n-ØD1	n-ØD2	d1	d2	g	重量 Weight (kg)	适用型号 Application type
DN40	60	200	80	160	140	4-Ø18	4-Ø14	125	105	2"	5.8	RSV-40
DN50	60	200	80	160	155	4-Ø18	4-Ø19	125	120	2"	6.5	RSV-50
DN65	76	200	90	180	175	4-Ø18	4-Ø19	145	140	2"	8.5	RSV-65
DN80	89	200	95	195	185	8-Ø18	8-Ø19	160	150	2"	9.5	RSV-80
DN100	108	200	105	215	210	8-Ø18	8-Ø19	180	175	2"	11.5	RSV-100
DN125	133	250	120	245	250	8-Ø18	8-Ø23	210	210	3"	15.5	RSV-125(A)
DN150	159	250	140	280	280	8-Ø23	8-Ø23	240	240	3"	18.5	RSV-150
DN200	219	300	165	335	330	8-Ø23	12-Ø23	295	290	4"	25	RSV-200(A)
DN250	273	300	195	390	400	12-Ø23	12-Ø25	350	355	4"	32.5	RSV-250
DN300	325	300	220	440	445	12-Ø23	16-Ø25	400	400	4"	39	RSV-300(A)



真空泄压阀

Vacuum pressure release valve

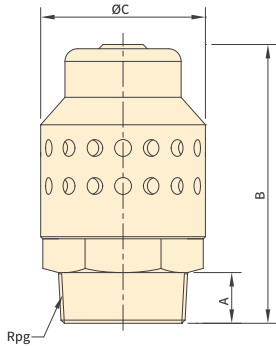

单位: Unit(mm)

型号 Type	A	B	C	g	重量 Weight (kg)	适用型号 Application type
2"	25	130	78	2"	0.8	RSV-40~100
3"	30	162	90	3"	1.4	RSV-125(A), 150
4"	35	168	128	4"	2.3	RSV-200(A), 250, 300

真空过滤桶

Vacuum filter vat

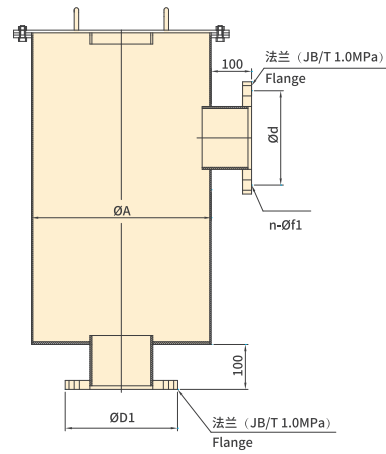
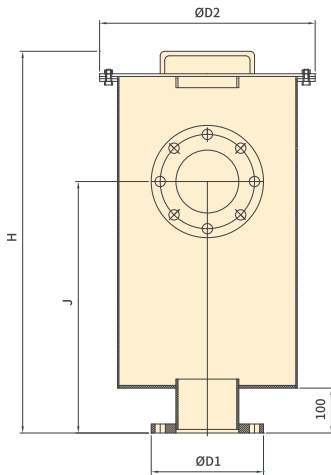

单位: Unit(mm)

型号 Type	J	H	D1	D2	n-Øf1	d	A	重量 Weight (kg)	适用型号 Application type
DN50	470	606	160	340	4-Ø18	125	260	30	RSV-40, 50
DN65	460	606	180	340	4-Ø18	145	260	34	RSV-65
DN80	500	695	195	360	8-Ø18	160	273	43	RSV-80
DN100	500	695	215	360	8-Ø18	180	273	48	RSV-100
DN125	560	796	245	480	8-Ø18	210	400	68	RSV-125(A)
DN150	560	796	280	480	8-Ø23	240	400	75	RSV-150
DN200	680	956	335	550	8-Ø23	295	470	120	RSV-200(A)
DN250	750	1026	390	550	12-Ø23	350	470	134	RSV-250
DN300	930	1243	440	580	12-Ø23	400	500	165	RSV-300(A)



真空弯头 Vacuum elbow

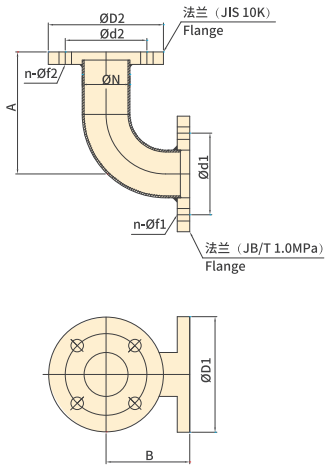

单位: Unit(mm)

型号 Type	N	A	B	D1	D2	n- $\varnothing f1$	n- $\varnothing f2$	d1	d2	重量 Weight (kg)	适用型号 Application type
DN50	60	200	110	160	155	4- $\varnothing 18$	4- $\varnothing 19$	125	120	5.2	RSV-40, 50
DN65	76	200	155	180	175	4- $\varnothing 18$	4- $\varnothing 19$	145	140	7.5	RSV-65
DN80	89	220	168	195	185	8- $\varnothing 18$	8- $\varnothing 19$	160	150	9	RSV-80
DN100	108	250	164	215	210	8- $\varnothing 18$	8- $\varnothing 19$	180	175	11.5	RSV-100
DN125	133	300	202	245	250	8- $\varnothing 18$	8- $\varnothing 23$	210	210	16	RSV-125(A)
DN150	159	320	240	280	280	8- $\varnothing 23$	8- $\varnothing 23$	240	240	20.5	RSV-150
DN200	219	315	315	335	330	8- $\varnothing 23$	12- $\varnothing 23$	295	290	30	RSV-200(A)
DN250	273	450	421	390	400	12- $\varnothing 23$	12- $\varnothing 25$	350	355	45	RSV-250
DN300	325	470	470	440	445	12- $\varnothing 23$	16- $\varnothing 25$	400	400	60	RSV-300(A)

弹性接头 Flexible connector

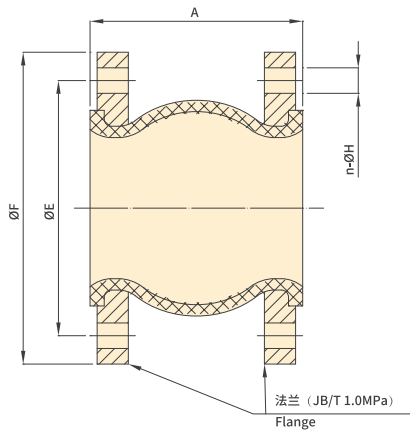

单位: Unit(mm)

型号 Type	A	E	F	n- $\varnothing H$	重量 Weight (kg)	适用型号 Application type
KXT50	105	125	160	4- $\varnothing 18$	3.72	RSV-40, 50
KXT65	115	145	180	4- $\varnothing 18$	4.68	RSV-65
KXT80	135	160	195	8- $\varnothing 18$	5.5	RSV-80
KXT100	150	180	215	8- $\varnothing 18$	6.7	RSV-100
KXT125	165	210	245	8- $\varnothing 18$	8.3	RSV-125(A)
KXT150	180	240	280	8- $\varnothing 23$	12	RSV-150
KXT200	190	295	335	8- $\varnothing 23$	14	RSV-200(A)
KXT250	230	350	390	12- $\varnothing 23$	18.6	RSV-250
KXT300	250	400	440	12- $\varnothing 23$	27.5	RSV-300(A)

用途说明 Applications

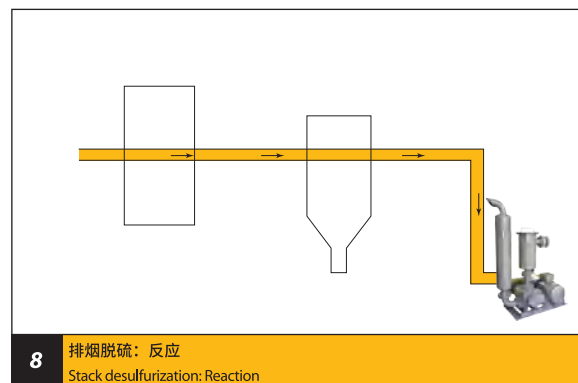
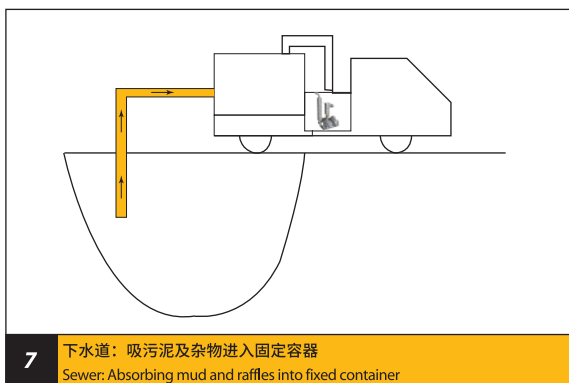
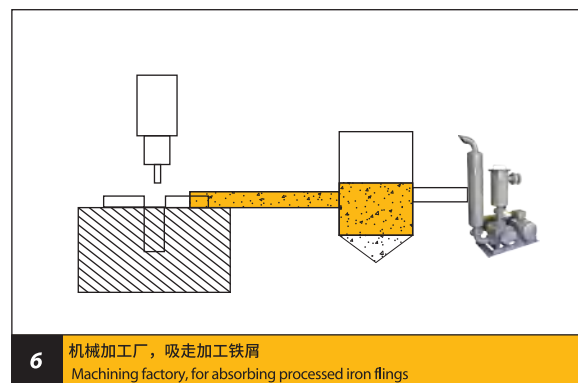
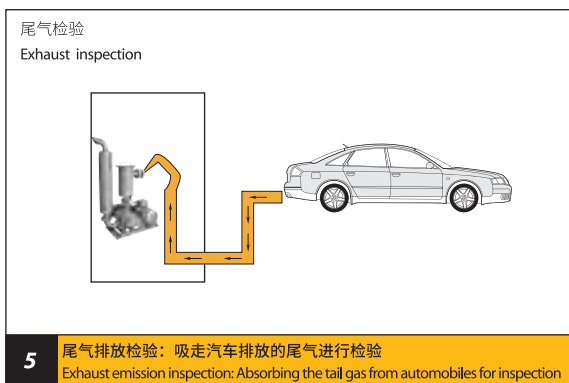
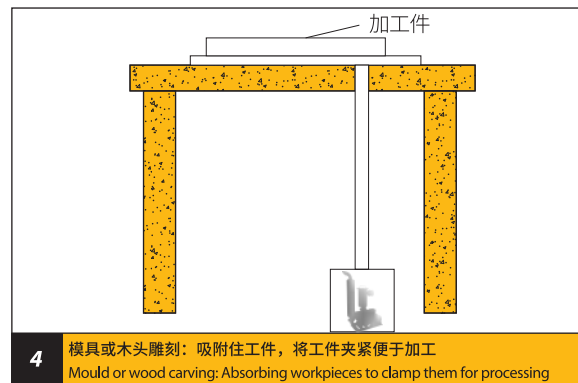
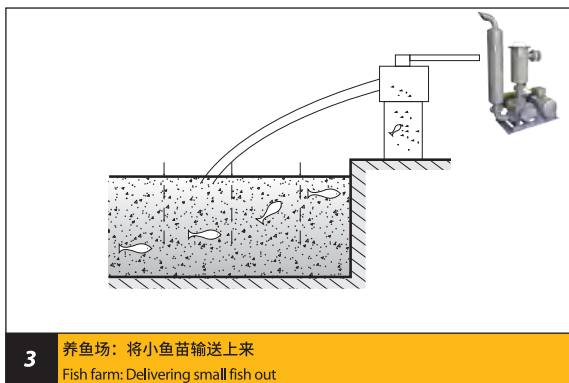
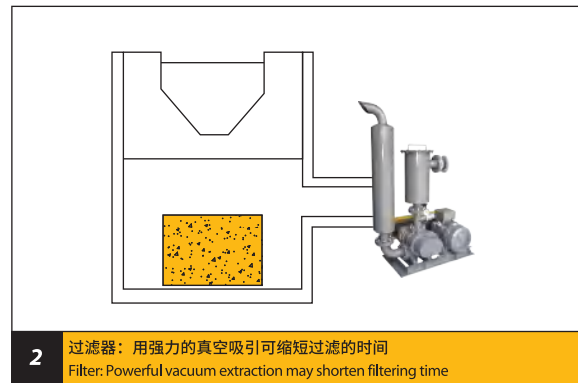
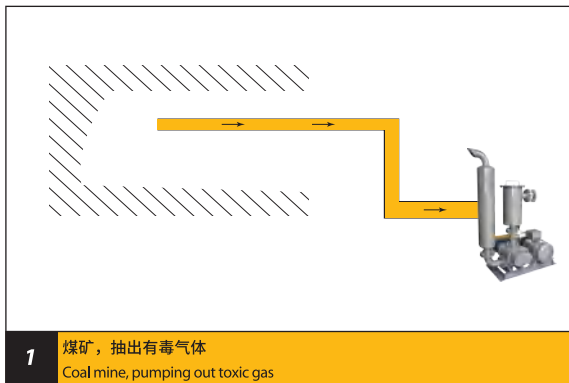

用途说明 Applications

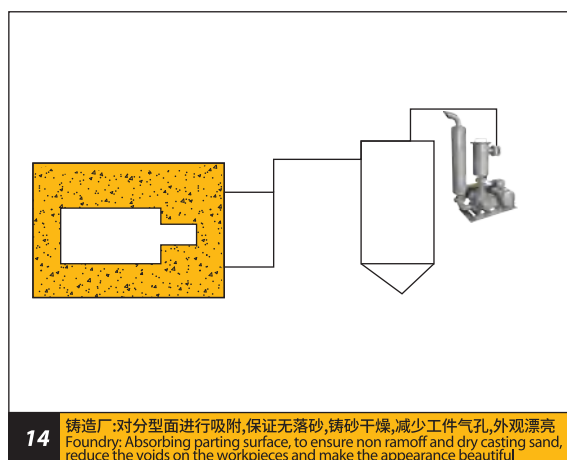
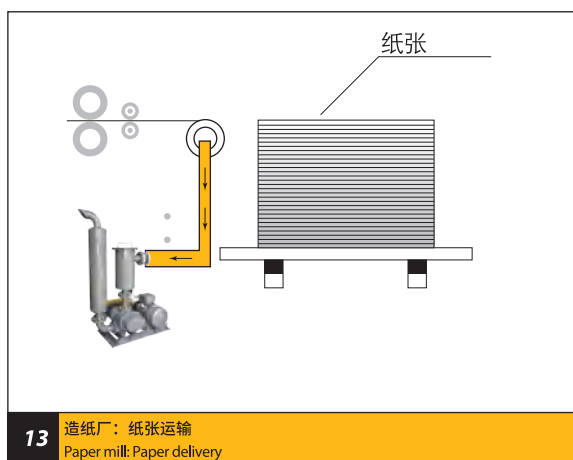
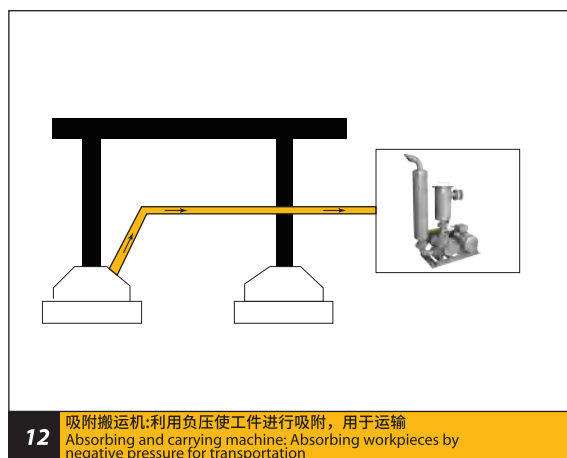
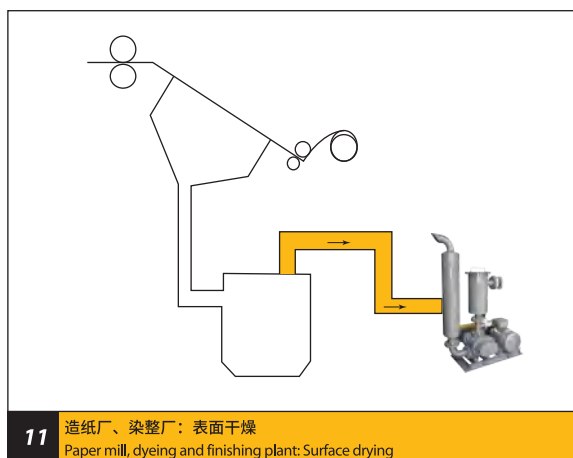
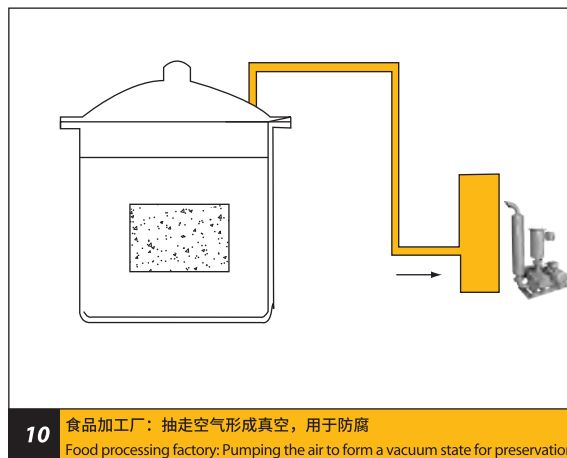
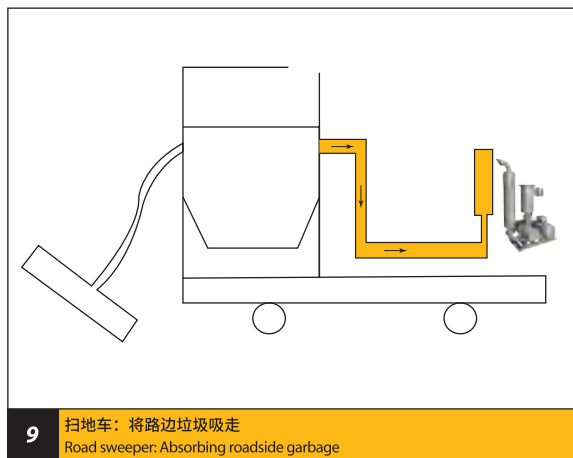

免费咨询电话

400-657-9066

本型录内容如有变更，恕不另行通知。
We reserve the right to change content without notice.

川源(中国)机械有限公司版权所有 all rights reserved. CY-34



扫一扫了解更多