



川源（中国）机械有限公司  
GSD Industrial Co.,Ltd.



# CG/CK

## 耐酸碱自吸式化学泵

**CG/CK Self-priming chemical pump**



# CG/CK 耐酸碱自吸式化学泵

## CG/CK Self-priming chemical pump

### 用途

- 化学药液或清水循环输送
- 包括电镀表面处理在内的各种镀液的循环输送
- 废水处理

### Application

- Chemical or water recirculation
- Plating solutions (include electroplating solution)
- Wastewater treatment



### 特点

- 泵浦材质依化学性需求不同有FRPP、PVDF、CPVC可供选择。
- 最高流体温度：  
CPVC75℃(167F)/FRPP80℃(176F)/PVDF85℃(185F)。
- 高效率，低操作成本，不泄漏，易于维护。
- 耐腐蚀性优良，所有金属零件不会接触到所抽送液体。
- 最大可靠度的独立止推轴承。
- 流体比重可达1.8。
- CG/CK系列于空转时，泵浦内的液体会经由循环回路冷却轴封，防止其过热损坏。

### Features

- CPVC, PVDF, or FRPP materials are on requests for different solutions.
- Max. fluid temperature:  
CPVC75℃(167F)/FRPP80℃(176F)/PVDF85℃(185F).
- High efficiency, low operation cost, leak-free operation and easy maintenance.
- Excellent chemical resistance.
- Independent thrust bearings for maximum reliability.
- Fluid specific gravity up to 1.8.
- For CG/CK series, cycling liquid cools the seal and prevents it from overheating while dry-running.

### 结构特性

- 采用不锈钢304加工制造的马达延长轴心连接到标准马达上，轴心配有铁氟龙轴套，使该轴心组合与所抽送的化学药水或溶液之间不会有接触。
- 机械轴封永远浸在溶液中，并以泵中抽送的溶液来做冷却，即使泵停机，轴封周遭也不会形成结晶。
- CG/CK型独家设计的轴封护罩，方便拆卸及更换。固定环座可采用耐高温PPS塑钢，空转时可承受130℃的高温，其泵体内残存的液体会经由铁氟龙循环管来冷却轴封。
- 特殊的铁氟龙弹性轴封设计，搭配各种材质的轴封如陶瓷、碳精、SIC及Hastelloy-C合金弹簧以确保优异的耐久及耐腐蚀性。固定环及转动环由SIC、碳素、陶瓷等各种不同的材质制成，适用于不同的化学药水。
- CG/CK型自吸式泵，自吸能力可达20英尺以上（出入口3”之机型无自吸能力）。

### Construction specifications

- The motor shaft extension is coupled to a standard motor and made of SUS304. A Teflon sleeve installing over the shaft does avoid the pumped chemicals or solution contacting between shaft and motor.
- The mechanical seal is always submerged in solution, and it is cooled by the solution in the pump. So crystals can not be formed around the seal when the pump is turned off.
- CG/CK series is with the unique seal assembly, and is easy to disassemble and replace. The fixed seal socket can be made of high temperature-resistant plastic PPS and is capable of operating up to 130℃ while dry running. The remained liquid inside the pump head runs through the Teflon hose and cools the seal while dry running.
- The unique Teflon bellows design with various seals such as Ceramic, Carbon, SIC and Hastelloy-C spring ensure excellent durability in corrosion resistance. Fixed-seal & rotationl-seal are made of various materials, SIC, Carbon, Ceramic and can withstand various chemicals.
- CG/CK series, designed with self-priming cover excellent self-priming performance up to 20 ft (3”in/outlet models cannot do self-priming well).



- 主体前盖法兰以热熔接合，密封性佳，可避免因塑钢本身的应力造成的缩水变型、真圆度不佳而密封不良。
- 泵出入口依型号及规格不同而有标准的1-1/2"、2"或3"等法兰接头。

- Symmetrical body structure eliminates leakage due to deforming caused by injection molding.
- The pump connections are standard 1-1/2", 2" or 3" flange connections depending on model and size.



## 型号说明 Type description

CG - 32 - 40H V F-CCH-H

- H: 有舌单向阀(With check lid)  
N: 无舌单向阀(Without check lid)
- 内装式轴封(Bulid in seal)  
CCH(SCH、CSH、SSH)
  - 弹簧(Spring) H: Hasteloy-c
  - 转动环(Rotatinal seal) C: Carbon S: SIC
  - 固定环(Fixed seal) C: Ceramic S: SIC
- 泵体材质(Material)  
F-FRPP C-CPVC P-PVDF
- 橡胶材质(Elastomer)  
N-NBR E-EPDM V-VITON T-TEFLON
- H: 高扬程(High head)  
L: 低扬程(Low head)
- 进出口径(In/Outlet diameter) mm
- 马力(Power) hp
- 相数(Phase): 1(单相) 3(三相)
- CG: 直联式(Coaxial volute pump);  
CK: 联轴式(Coupling pump)



## 结构简图 Construction

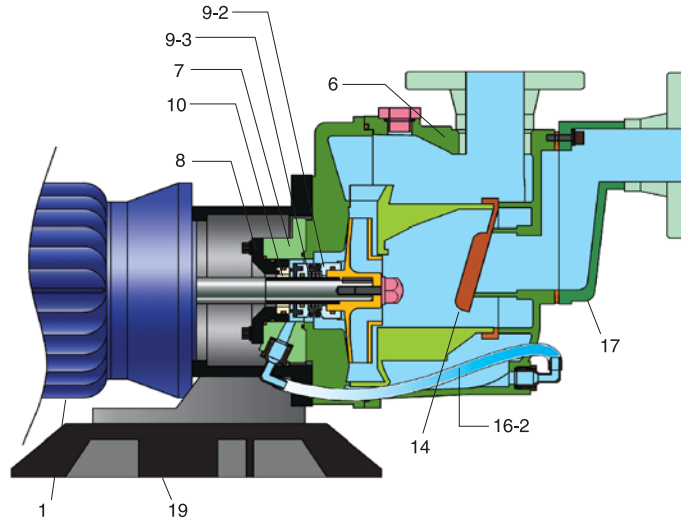

## 组合示意图 Assembled schematic diagram

CG  
1~5 hp  
0.75~3.7 kW

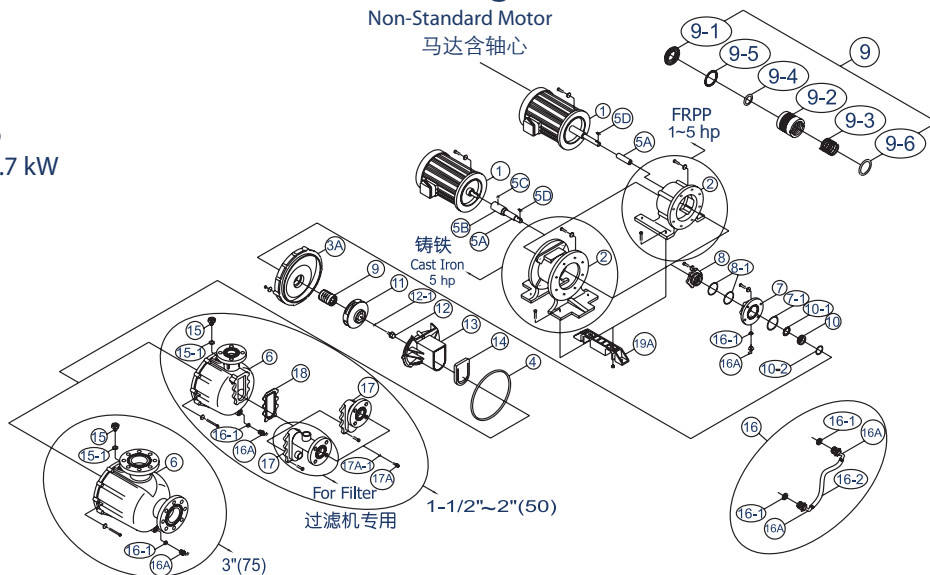

CK  
2~10 hp  
1.5~7.5 kW

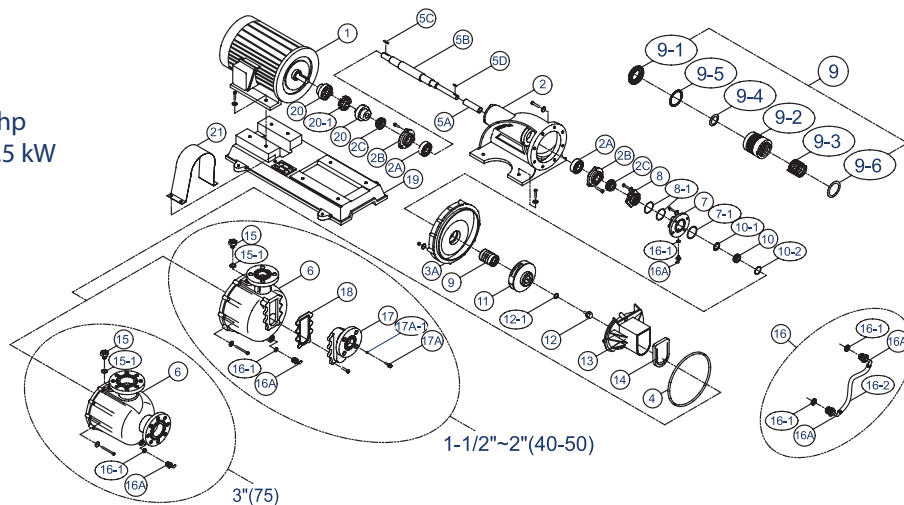

NO.	名称	Name	材质 Material
1	马达	Motor	FC
2	脚座	Frame	FC/FRPP
2A	脚座轴承	Frame bearing	STEEL
2B	轴承防尘盖	Bearing dust shield	FC
2C	轴承防水套	Bearing liquid shield	PP
3A	后封盖	Rear cover	FRPP/CPVC/PVDF
4	后盖O环	Rear cover O-ring	NBR/EPDM/MTON
5A	轴套	Shaft sleeve	TEFLON
5B	轴心	Shaft	SUS
5C	轴心固定螺丝	Shaft screw	SUS
5D	叶轮键	Impeller key	SUS
6	主体前盖	Front cover	FRPP/CPVC/PVDF
7	轴封护罩	Seal cover	FRPP/CPVC/PVDF
7-1	轴封护罩O环	Seal cover O-ring	NBR/EPDM/MTON
8	固定环座	Fixed-seal socket	PPS/FRPP/CPVC/PVDF
8-1	固定环座O环	Fixed-seal socket O-ring	NBR/EPDM/MTON
9	前轴封	Bellows-seal combination	-
9-1	转动环	Rotational-seal	CARBON/SIC
9-2	伸缩环	Bellows	TEFLON
9-3	弹簧	Bellows spring	HASTELLOY-C/SUS316
9-4	伸缩环前O环	Bellows front O-ring	NBR/EPDM/MTON
9-5	伸缩环垫片	Bellows packing	NBR/EPDM/MTON
9-6	伸缩环后O环	Bellows rear O-ring	NBR/EPDM/MTON
10	固定环	Fixed-seal	CERAMIC/SIC

NO.	名称	Name	材质 Material
10-1	固定环后O环	Fixed-seal rear O-ring	NBR/EPDM/MTON
10-2	固定环O环	Fixed-seal O-ring	NBR/EPDM/MTON
11	叶轮	Impeller	FRPP/CPVC/PVDF
12	叶轮螺丝	Impeller screw	FRPP/CPVC/PVDF
12-1	叶轮螺丝O环	Impeller screw O-ring	NBR/EPDM/MTON
13	中封盖	Check cover	FRPP/CPVC/PVDF
14	单向阀	Check valve	NBR/EPDM/MTON/TEFLON
15	注水盖	Water filling cap	FRPP/CPVC/PVDF
15-1	注水盖O环	Water filling cap O-ring	NBR/MTON/EPDM
16	循环管含接头	Recycle hose	TEFLON
16-1	循环接头垫片	Recycle joint packing	NBR/EPDM/MTON
16-2	铁氟龙管	Teflon hose	TEFLON
16A	循环接头	Recycle joint	PVDF
16B	塞头	Plug	FRPP
17	自吸筒	Self-priming cover	FRPP/CPVC/PVDF
17A	自吸筒螺丝	Self-priming cover screw	PVDF/SUS
17-1	自吸筒螺丝O环	Cover screw O-ring	NBR/EPDM/MTON
18	自吸筒垫片	Self-priming cover packing	NBR/EPDM/MTON/TEFLON
19	CK底座	Base for CK	FC
19A	CG/CK脚架	Base for CG/CK	FRPP
20	联轴器	Coupling	FC
20-1	联轴器橡胶	Coupling elastomer	NBR
21	联轴器护罩	Coupling shield	SUS

## 性能曲线 Performance curves

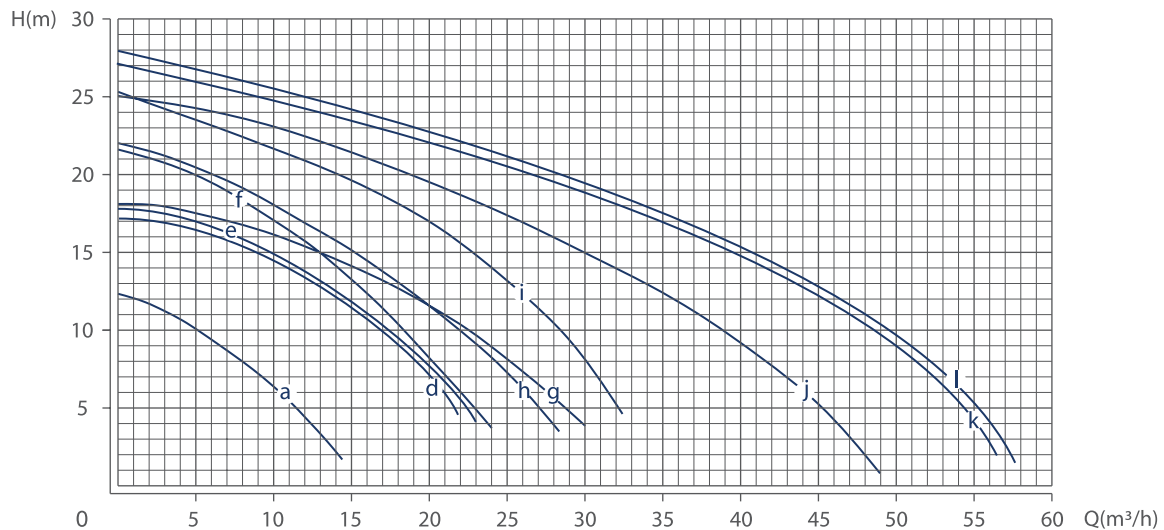

## 性能参数 Performance parameters

Testing fluid:water(specific gravity 1.0)

泵型号 Pump type	进出口 In/outlet (mm)	相数 Phase	功率 Power (kW)	极数 Pole	曲线 Curve	扬程 Head (m)	流量 Capacity (m <sup>3</sup> /h)	泵重量 Weight kg
CG-31-40H	40 x 40	3	0.75	2	a	8.0	8.0	31
CG/CK-32-40L	40 x 40	3	1.5	2	d	11.5	11.0	39/75
CG/CK-32-40H	40 x 40	3	1.5	2	e	10.3	11.8	39/75
CG/CK-33-40H	40 x 40	3	2.2	2	f	13.8	14.5	43/80
CG/CK-33-50L	50 x 50	3	2.2	2	g	11.5	20.0	43/80
CG/CK-33-50H	50 x 50	3	2.2	2	h	14.0	16.5	43/80
CG/CK-35-50H	50 x 50	3	3.7	2	i	16.0	21.5	55(70#)/83
CG/CK-35-75H	75 x 75	3	3.7	2	j	18.0	23.0	56(71#)
CK-37-75H	75 x 75	3	5.5	2	k	19.5	28.0	120
CK-310-75H	75 x 75	3	7.5	2	l	20.3	26.5	125

重量值均是以FRPP材质为准，注明#者为CG机种3.7 kW搭配铸铁脚座之重量。

The pump weight is based on FRPP material. The weight are marked with "#" are the weight of CG series 3.7 kW with cast iron frame out.

※CG 3.7 kW机型脚座有FRPP及铸铁两种。

※Frame out of FRPP or cast iron are available for CG 3.7 kW model.

## 脚座使用说明 Notes of frame

塑钢脚座

FRPP Frame



铸铁脚座

5 hp 马达标准专用

Cast Iron Frame

for 5 hp motor only



本公司内部规格：CG机种，5 hp机型均采用3 hp机型之塑钢脚座，搭配非国际标准马达，其框号为AVEF-100L。

特殊选择：搭配国际标准马达，框号为AVEF-112M，是采用铸铁脚座，其型号标示方式如下：在型号后面加上代码F。

范例：CG-35-75HVC-CCH-N-F

For our 5 hp model, the motor casing is same as the one for 3 hp motor (No.AVEF-100L) to conform to our FRPP frame. Hence the standard 5 hp motor can not match this frame.

Option: for our 5 hp model with standard motor, the casing No. of motor which conform to our cast iron frame is AVEF-112M, and name the model as following: add a code "F" behind the mode name.

For example: CG-35-75HVC-CCH-N-F

## 外形及安装尺寸 Installation dimensions

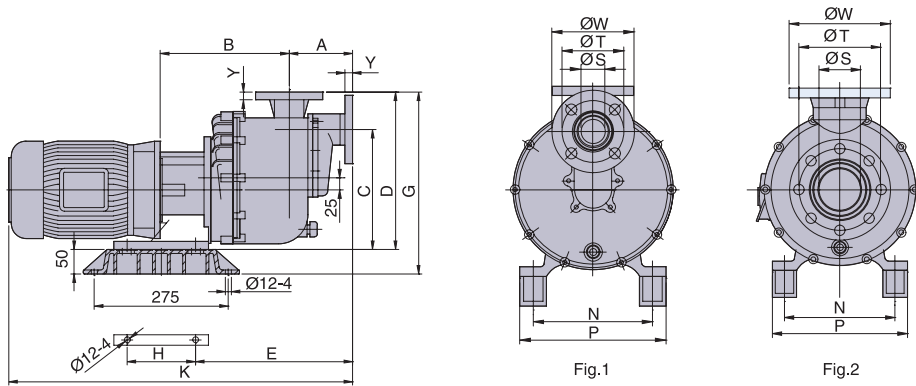

配FRPP脚座 Dimension table(with FRPP frame)

单位(Unit): (mm)

型号 Type	FIG.	A	B	C	D	E	G	H	K	N	P	S	T	W	Y
CG-31-40H	1	128	265	250	325	313	375	140	623	205	250	40	105	140	14
CG-32-40H(L)	1	128	265	250	325	313	375	140	701	205	250	40	105	140	14
CG-33-40H	1	128	265	250	325	313	375	140	701	205	250	40	105	140	14
CG-33-50H(L)	1	128	265	250	325	313	375	140	701	205	250	50	120	155	16
CG-35-50H	1	128	265	250	325	313	375	140	740	205	250	50	120	155	16
CG-35-75H	2	123	315	150	336	360	386	140	800	205	250	75	150	185	18

配铸铁脚座 Dimension table(with Cast Iron frame)

单位(Unit): (mm)

型号 Type	FIG.	A	B	C	D	E	G	H	K	N	P	S	T	W	Y
CG-35-50H	1	128	290	295	362	263	390	160	813	190	250	50	120	155	16
CG-35-75H	2	123	330	186	370	308	420	160	870	190	250	75	150	185	18

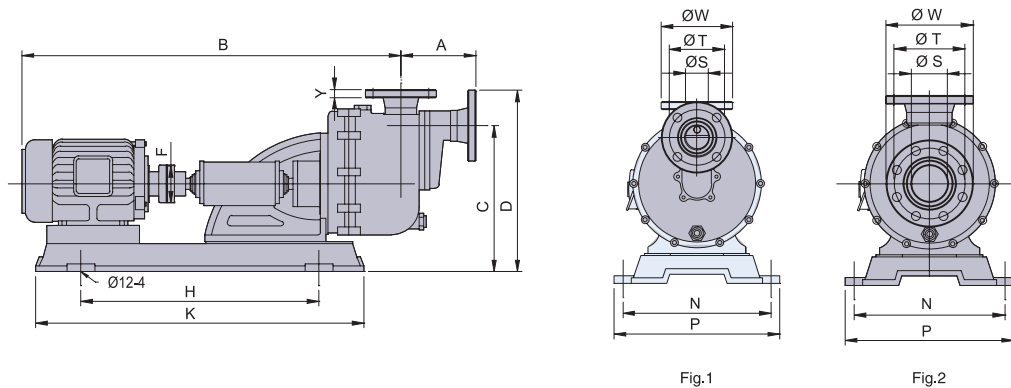

Fig.1

Fig.2

单位(Unit): (mm)

型号 Type	FIG.	A	B	C	D	F	H	K	N	P	S	T	W	Y
CK-32-40L	1	128	830	312	390	82	525	710	320	362	40	105	140	14
CK-32-40H	1	128	830	312	390	82	525	710	320	362	40	105	140	14
CK-33-40H	1	128	830	312	390	82	525	710	320	362	40	105	140	14
CK-33-50L	1	128	830	312	390	82	525	710	320	362	50	120	155	16
CK-33-50H	1	128	830	312	390	82	525	710	320	362	50	120	155	16
CK-35-50H	1	128	885	312	390	82	525	710	320	362	50	120	155	16
CK-35-75H	2	123	935	224	410	82	525	710	320	362	75	150	185	18
CK-37-75H	2	123	1015	224	410	97	590	780	320	362	75	150	185	18
CK-310-75H	2	123	1015	224	410	97	590	780	320	362	75	150	185	18



## 如蒙洽询请指示下列各项

### For further details, please fulfill the chart below.

客户 Customer \_\_\_\_\_ 承办人员 Undertaker \_\_\_\_\_

工程名称 Name of project \_\_\_\_\_ 工程地点 Address of project \_\_\_\_\_

电话 Telephone \_\_\_\_\_ 传真 Fax \_\_\_\_\_

*行业类别 Industry type	<input type="checkbox"/> 金属制品制造厂 Metal products factory	<input type="checkbox"/> 代工电镀厂 OEM electroplating factory
	<input type="checkbox"/> 涂装工厂 Coating plant	<input type="checkbox"/> 电子半导体制造厂 Electronic semiconductor manufacturing
	<input type="checkbox"/> 铝阳极处理厂 Anodized aluminum plant	<input type="checkbox"/> 染整厂 Dyeing and finishing plant
	<input type="checkbox"/> 金属加工生产电镀 Plating metal processing	<input type="checkbox"/> 涂装设备制造商 Painting equipment manufacturers
	<input type="checkbox"/> 电子PC板制造厂 Electronic PC board manufacturing factory	<input type="checkbox"/> 电子零件加工厂 Electronic parts plant
	<input type="checkbox"/> 皮革厂 Leather factory	<input type="checkbox"/> 制药厂 Pharmaceutical factory
	<input type="checkbox"/> 其它 Other	
化学液 Chemical ingredience	*名称 Name:	*温度 Temperature: _____ C
	*酸碱度 pH:	*比重 Specific gravity:
	*黏度 Viscosity: _____ CPS	*杂质 Contain other solid: <input type="checkbox"/> 有 Yes _____ <input type="checkbox"/> 无 No
*运行条件 Operation requirement (运行工况点) Operation point	*必要吐出量 Capacity: _____ m <sup>3</sup> /h	
	*扬程 Head: _____ m	
	*日运行时间 Daily operation time: _____ h	
环境 Environment	安装场所 Installation location: <input type="checkbox"/> 室内 Indoor <input type="checkbox"/> 室外 Outdoor	
	使用方法 Operation method: <input type="checkbox"/> 移动式 Mobile <input type="checkbox"/> 固定配管 Fixed piping <input type="checkbox"/> 其它: Other _____	
	使用温度 Operation temperature: <input type="checkbox"/> 常温 Room temperature <input type="checkbox"/> 温度 Temperature: _____ C	
使用条件 Use requirement	吸入口 Suction inlet: (液体比泵浦入口 the water level of the Liquid) <input type="checkbox"/> 高 Higher <input type="checkbox"/> 低 Lower	
	*电源 Power: <input type="checkbox"/> 单相 Single phase <input type="checkbox"/> 三相 Three phase	
	其它 Others:	
其它要求 Other requests		

备注: 1. 以上资料请尽可能完整填写。  
2. 项目前加注“\*”者, 请务必填写。

Notes: 1. Please fill in the parameter lists as complete as possible.  
2. The item with "\*" must be filled.

免费咨询电话

# 400-657-9066

本型录内容如有变更, 恕不另行通知。  
We reserve the right to change content without notice.

CY-G7

